



# Reflex 75T

Inset Convector Fire - Balanced Flue  
with Harmony 10 Remote Control System



## User & Installation Instructions

### IMPORTANT

THE OUTER CASING, FRONT AND GLASS PANEL BECOME EXTREMELY HOT DURING OPERATION AND WILL RESULT IN SERIOUS INJURY AND BURNS IF TOUCHED. IT IS THEREFORE RECOMMENDED THAT A FIREGUARD COMPLYING WITH BS 8423 (LATEST EDITION) IS USED IN THE PRESENCE OF YOUNG CHILDREN, THE ELDERLY OR INFIRM.

This product contains a Heat resistant glass panel. This panel should be checked during Installation and at each servicing interval. If any damage is observed on the front face of the glass panel (scratches, scores, cracks or other surface defects), the glass panel must be replaced and the appliance must not be used until a replacement is installed. Under no circumstances should the appliance be used if any damage is observed, the glass panel is removed or broken.

It is essential that ALL of the screws that retain the glass frame are replaced and tightened correctly. Under no circumstances should the appliance be operated if any of these screws are loose or missing.

These Instructions must be left with the appliance for future reference and for consultation when servicing the appliance. Please make the customer aware of the correct operation of the appliance before leaving these instructions with them.

The commissioning sheet found on Page 3 of this Instruction manual must be completed by the Installer prior to leaving the premises.

# CONTENTS

## REFLEX 75T - BALANCED FLUE

Covering the following models:

	REFLEX 75T NAT GAS	REFLEX 75T LPG
Black Reeded	191-082	191-471
Vermiculite	191-094	191-487
Brick Effect	191-106	191-490
Ledgestone	191-111	191-512
Black Glass	191-127	191-528

**Appliance Commissioning Checklist .....3**

**User Instructions .....4**

**Installation Instructions .....12**

Technical Specifications ..... 15

Site Requirements ..... 18

Installation .....23

Commissioning ..... 44

**Servicing Requirements .....45**

Fault Finding ..... 45

How to replace parts ..... 48

Spare parts list .....58

Information Requirement - Gas Heaters .....60

Service Records ..... 61



It is a requirement of the Building Regulations 2010 that the installation of this appliance is notified to the Local Authority. It is the responsibility of the GasSafe registered installer to carry out this notification to the Local Authority via the GasSafe register Competent Persons Scheme in England and Wales (different rules apply in Scotland and Northern Ireland).

When the installation has been notified, GasSafe will send a Building Regulations Compliance Certificate to you containing details of the work completed. Please ensure that the person responsible for the installation of this appliance completes this notification and records it in the Appliance Commissioning Checklist on page 3.

**IT IS YOUR RESPONSIBILITY TO COMPLY WITH THE BUILDING REGULATIONS AND BE ABLE TO PRODUCE THIS CERTIFICATE SHOULD IT BE REQUIRED IN THE FUTURE.**

# APPLIANCE COMMISSIONING CHECKLIST

To assist us in any guarantee claim please complete the following information:-

## IMPORTANT NOTICE

Explain the operation of the appliance to the end user, hand the completed instructions to them for safe keeping, as the information will be required when making any guaranteed claims.

FLUE CHECK	PASS	FAIL
1. Flue Is correct for appliance		
2. Flue flow Test N/A		
3. Spillage Test N/A		
GAS CHECK		
1. Gas soundness & let by test		
2. Standing gas pressure	mb	
3. Appliance working pressure (on High Setting) Minimum Pressure Requirement: NG - 17.5mbar LPG - 34.5mbar NB All other gas appliances must be operating on full	mb	
4. Gas rate	m <sup>3</sup> /h	
5. Does Ventilation meet appliance requirements N/A		
SAFETY CHECK		
1. Check soundness of the Thermocouple connections - including tightness and lead integrity		
2. Glass checked to ensure no damage, scratches, scores or cracks		
3. Glass frame secured correctly and all screws replaced		
BUILDING CONTROL NOTIFICATION		
	YES	NO
1. Installer notified Local Authority of installation via Competent Persons Scheme?		

## RETAILER AND INSTALLER INFORMATION

<b>Retailer</b> .....	<b>Installation Company</b> .....
.....	.....
.....	.....
<b>Contact No.</b> .....	<b>Engineer</b> .....
<b>Date of Purchase</b> .....	<b>Contact No.</b> .....
<b>Model No.</b> .....	<b>GasSafe Reg No.</b> .....
<b>Serial No.</b> .....	<b>Date of Installation</b> .....
<b>Gas Type</b> .....	

## GENERAL

Installation and servicing must only be carried out by a competent person whose name appears on the Gas Safe register. To ensure the engineer is registered with Gas Safe they should possess an ID Card carrying the following logo:



In all correspondence, please quote the appliance type and serial number, which can be found on the data badge located on a plate under the Main Burner.

Do not place curtains above the appliance: You must have 500mm clearance between the appliance and any curtains at either side.

No furnishings or other objects should be placed within 1 metre of the front of the appliance

If any cracks appear in the glass panels do not use the appliance until the panels have been replaced.

If, for any reason, the flue has to be removed from the appliance, the seals must be replaced in the inner spigot.

Do not obstruct the flue terminal in any way, i.e. by planting flowers, trees, shrubs etc. in the near vicinity, or by leaning objects against the terminal guard.

Do not put any objects on the terminal guard; it will lose its shape.

If you use a garden sprinkler, do not let quantities of water into the flue terminal.

When the appliance has been installed the position of the plug must be accessible.

Where the electricity supply cable has to pass through a **fire place, stone surround etc. ensure suitable rubber bushes are fitted at possible wear points.**

If the electricity supply cable is damaged do not use the appliance until it has been replaced. For safety reasons the replacement has to be carried out by Gazco, a Gazco service agent or a similarly competent electrician.

Repairs of electrical appliances must only be performed by an electrical engineer. Should the appliance fail to operate, or in case of any damage, please contact the retailer from whom the appliance was purchased.

This product is guaranteed for 5 years from the date of installation, as set out in the terms and conditions of sale between Gazco and your local Gazco retailer. Please consult with your local Gazco retailer if you have any questions. In all correspondence always quote the Model Number and Serial Number.

**This appliance is not intended to be used by persons under the age of 12, persons with reduced physical, sensory or mental capabilities or persons with lack of experience and knowledge in the safe operation of the appliance.**

The appliance may be operated by persons above the age of 12 provided they have been instructed in the safe use of the appliance and that they understand the hazards involved. Persons above the age of 12 may also operate the appliance under the supervision of a responsible adult.

Cleaning and Maintenance of the appliance must be undertaken by a suitably qualified adult.

**CHILDREN MUST BE SUPERVISED TO ENSURE THEY DO NOT PLAY WITH THE APPLIANCE.**



**IMPORTANT: NEVER position a television or screen above this appliance.**

## WARNING



**In the event of a gas escape or if you can smell gas, please take the following steps:**

- **Immediately turn off the gas supply at the meter/emergency control valve**
- **Extinguish all sources of ignition**
- **Do not smoke**
- **Do not operate any electrical light or power switches (On or Off)**
- **Ventilate the building(s) by opening doors and windows**
- **Ensure access to the premises can be made**

**Please report the incident immediately to the National Gas Emergency Service Call Centre on 0800 111 999 (England, Scotland and Wales), 0800 002 001 (N. Ireland) or in the case of LPG, the gas supplier whose details can be found on the bulk storage vessel or cylinder.**

**The gas supply must not be used until remedial action has been taken to correct the defect and the installation has been recommissioned by a competent person.**

## OPERATING THE APPLIANCE

The appliance is operated by thermostatic and programmable remote control.



Via the remote it is possible to control the following features:

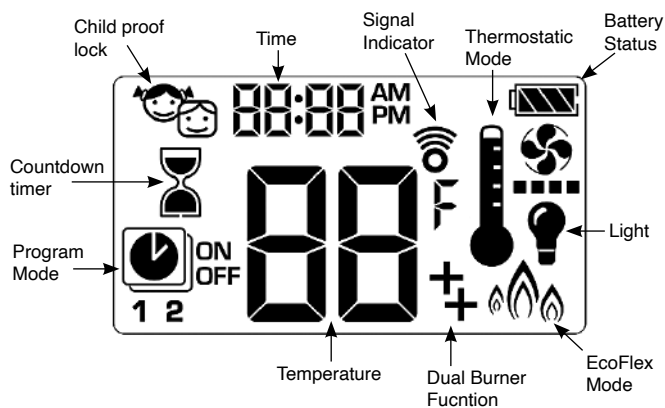

## BEFORE OPERATING

Make sure manual knob on the gas valve is in the ON position by turning fully clockwise to the position.

## TURNING THE APPLIANCE ON

The handset controls the appliance from pilot ignition through to shut down.

To turn the fire on press the button until two short signals and a series of blinking series of lines confirm the start of the ignition sequence.

**The pilot will ignite and the remote is now in Manual Mode:**

**i** **IMPORTANT: YELLOW FLAMES TYPICALLY APPEAR WHEN THE APPLIANCE HAS REACHED NORMAL OPERATING TEMPERATURE. THIS CAN TAKE UP TO 30 MINUTES.**

**!** **WARNING: IF THE APPLIANCE FAILS TO LIGHT OR BECOMES EXTINGUISHED IN USE, WAIT 3 MINUTES BEFORE ATTEMPTING TO RELIGHT.**

There are 4 different modes available for controlling and operating the appliance:

1. Manual Mode
2. Thermostatic Mode (Automatic)
3. Program Mode (Automatic)
4. EcoFlex Mode (Automatic)

In **MANUAL MODE** you can:

- turn on the main burner using the button.
- regulate the flame from high to low and back.
- turn off the burner leaving just the pilot burning.

In **THERMOSTATIC MODE (Automatic)** you can:

- set the room temperature so the thermostat in the remote automatically maintains that temperature.

In **PROGRAM MODE (Automatic)** the fire:

- turns on and off according to the set time periods.
- automatically regulates the room temperature during the set periods.

In **ECOFLEX MODE (Automatic)** the fire:

- modulates the flame height between high and low in response to room temperature. One cycle lasts for 20 minutes.

**i** **NOTE: When operating the fire in Thermostatic or Program mode, the pilot remains lit and the fire then automatically switches on to bring the room to the set temperature whether or not you are in the room.**

**NEVER LEAVE ANY COMBUSTIBLE MATERIALS WITHIN 1 METRE OF THE FRONT OF THE APPLIANCE.**

## TURNING THE APPLIANCE OFF (STANDBY)

Press and hold the button to turn the appliance off.

NOTE: There is a 5 second delay before the next ignition is possible.

## MANUAL MODE

To turn the fire on press the button until two short signals and a series of blinking series of lines confirm the start of the ignition sequence.

### Standby By (Pilot Flame) Mode:

Press and hold the button to set the appliance to pilot flame only.

**FOR SAFETY, YOU MUST WAIT 30 SECONDS BEFORE LIGHTING THE FIRE AGAIN.**

### Increasing the Flame Height:

To increase flame height press and hold button.

### Decreasing the Flame Height:

To decrease flame height press or to set the appliance to pilot flame and hold the button.

**NOTE: While pressing a button a symbol indicating transmission appears on the display. The receiver confirms transmission with a sound signal.**

## THERMOSTATIC MODE (AUTOMATIC)

To select the Thermostatic mode press the button. The preset temperature will show briefly then the current **room** temperature will be displayed.

### Setting the temperature:

Press and hold the button until the temperature display flashes.

Adjust the temperature by pressing the or button.

Press the button to confirm the temperature.

**NOTE: If you set a temperature that is beneath the current room temperature, the fire automatically switches to PILOT (Standby).**

### Exiting Thermostatic Mode:

Press the button to exit Thermostatic mode.

Press the or button to enter Manual Mode.

Press the button to enter Program Mode.

Press the button to enter EcoFlex Mode.

## PROGRAM MODE (AUTOMATIC)

To select the Program mode press the button. The set temperature for the On time is the one set in Thermostatic Mode. Changing the thermostat temperature changes the temperature in Program mode.

### Default Settings

The On time (Thermostatic) Temperature is 21°C (70°F).  
The Off time Temperature is '-' (Pilot flame only).

### Temperature Settings

Press the button and hold until the display flashes ON and set the temperature (See Thermostatic Mode) is displayed.

Press the button or wait until OFF is displayed and the temperature flashes.

Adjust the temperature by pressing the or button.

Press the button to confirm the temperature.

NOTE: The On (Thermostatic) and Off set temperature is the same for each day.

### Day Setting:



ALL Flashes. Press or button to choose between ALL, SA, SU, 1, 2, 3, 4, 5, 6, 7.

Press the  button to confirm.



**ALL Selected**

**ON TIME SETTING (PROGRAM 1):**

 , 1 ON displayed, ALL is displayed shortly and **hour** flashes.

Select the **hour** by pressing the  or  button.



Press the  button to confirm.  , 1 ON displayed, ALL is displayed shortly and **minutes** flashes.

Select the **minutes** by pressing the  or  button.



Press the  button to confirm.

**OFF TIME SETTING (PROGRAM 1):**

 , 1 OFF displayed, ALL is displayed shortly and **hour** flashes.

Select the **hour** by pressing the  or  button.

Press the  button to confirm.  , 1 OFF displayed, ALL is displayed shortly and **minutes** flashes.

Select the **minutes** by pressing the  or  button.

Press the  button to confirm.

**i** **NOTE: either continue to PROGRAM 2 and set on and off times or stop programming at this point and PROGRAM 2 remains deactivated.**

**PROGRAM 1 and PROGRAM 2 use the same On (Thermostatic) and Off temperatures for ALL, SA:SU and Daily Timer (1, 2, 3, 4, 5, 6, 7). Once a new On (Thermostatic) and/or Off temperature has been set, that temperature becomes the new default setting.**

**If ALL, SA:SU or Daily Timer are programmed for PROGRAM 1 and PROGRAM 2 On and Off times these become the new default times. The batteries must be removed to clear PROGRAM 1 and 2 On and Off times and temperatures.**

**SA:SU or Daily (1, 2, 3, 4, 5, 6, 7) selected**

Set On and Off time using the same procedure as 'ALL Selected' (above).

SA:SU: Set On and Off time for both Saturday and Sunday.

Daily Timer: Unique On and Off times might be set for a single day of the week for multiple days of the week or for every day of the week.

Wait to finish setting.

**Exiting Program Mode:**



Press the ,  or  button to enter Manual Mode.

Press the  button to enter Thermostatic mode.

Press the  button to enter EcoFlex Mode.

**ECOFLEX MODE**

**Turning the EcoFlex Mode on.**

Press the  button to enter EcoFlex Mode.  is displayed.

**Turning the EcoFlex Mode off.**

Press the  button to exit EcoFlex Mode.  will disappear.

**DESIGNATED HIGH AND LOW FIRES**

**i** **NOTE: Backlight must be on for high and low fire double click operation.**



To go to Low fire, double click the  button. LO is displayed.



Flame goes to high fire first before going to Low fire.

To go to Hi fire, double click the  button. HI is displayed.

**DUAL BURNER FUNCTION**



Upon ignition Burner 1 is on and Burner 2 is in the last setting. Both sides can be activated or controlled using the Dual Burner Function.

Press and hold the  button to enter Dual Burner Function and turn on burner 2.  is displayed.

Press and hold the  button to exit Dual Burner Function leaving only burner 1 in operation.  will disappear.



**LIGHT/DIMMER OPERATION**



**Turning the light on.**



Press the  button to operate.  is displayed.

The lights on at preset level.



**SETTING:**

Press the  button and hold until  is flashing.

To adjust the lighting between 20 % and 100% press the  or  button.

To confirm setting either press the  button or wait (  is displayed).

**Turning the light off.**

Press the  button to turn off.  disappears.

**i** **NOTE: The light works independently of the Pilot flame. If you want the light on but no flame press the button to operate.**

## COUNTDOWN TIMER

### Turning the Timer on.

Press and hold the button until displayed, and hour flashes.

To select the **hour** press the or button.

To confirm press the button. **Minutes** flash.

To select the **minutes** press the or button.

To confirm press the button or wait.

### Turning the Timer off.

Press and hold the button, and countdown display will disappear.

**At the end of countdown time period, the appliance turns off. The Countdown Timer only works in Manual, Thermostatic and EcoFlex modes. Maximum countdown time is 9 hours and 50 minutes.**

## CHILD PROOF LOCK

### Turning the Child Lock on.

Press the and buttons simultaneously. will be displayed and the handset is rendered inoperable except for the Off function.

### Turning the Child Lock off.

Press the and buttons simultaneously to deactivate.

will disappear.

## SETTING THE TIME

Press the and buttons simultaneously. **Day** flashes.

Press the or button to select a number that corresponds with a day of the week (eg 1 = Monday, 2 = Tuesday, 3 = Wednesday, 4 = Thursday, 5 = Friday, 6 = Saturday, 7 = Sunday).

Press the and buttons simultaneously. **Hour** flashes.

To select hour press the or button.

Press the and buttons simultaneously. **Minutes** flash.

To select minutes press the or button.

To confirm press the and buttons simultaneously or wait.

## SETTING FAHRENHEIT OR CELSIUS

To change between °C and °F press and buttons simultaneously.

**NOTE: Choosing °F results in a 12 hour clock. Choosing °C results in a 24 hour clock.**

## TROUBLESHOOTING



**IMPORTANT: In the unlikely event that the handset fails to communicate correctly with the appliance it may be necessary to turn off the gas supply at the isolation valve until any problems can be resolved.**

The gas meter and isolation valve can be located outside in a meter box, under the stairs, beneath the kitchen sink or in the garage. Whilst this list is not exhaustive, it is important to be able to identify the location of the valve in case of any gas emergency.

To turn off the gas supply, simply turn the handle so the lever is at 90 degrees to the upright gas pipe.

**If you smell gas, open doors and windows and never operate any electrical switches. Immediately call the Gas Emergency Services on 0800 111 999.**



## MYFIRE WI-FI KIT

This appliance can be fitted with an optional Wi-Fi kit which can allow operation from a tablet or smart device:  
 Gazco part No. 999-055.  
 Contact your Gazco retailer for more information.

## MYFIRE WI-FI TROUBLESHOOTING

The MyFire Wi-Fi box must be wired according to the MyFire set up diagram and connected to the receiver, which is in turn connected to the mains power.

Ensure the device is running the most up to date operating system as older models may not be compatible with the MyFire App.

After 30 seconds the MyFire Box goes into Access Point Mode (Green LED flashes). See MyFire App instructions supplied and configure the router.

The following things can affect the Wi-Fi signal on the appliance:

1. Multiple users on the same Wi-Fi channel may interfere with the data transfer. Press the reset button on the MyFire Wi-Fi box for 1 second to change the current channel.
2. If the MyFire Wi-Fi box is not connected to the receiver or is not used it will leave Access Point Mode after 24 hours.
3. If there are multiple fireplaces in the household using MyFire Wi-Fi boxes there must be a minimum of 600mm between them to avoid interference.
4. If there are any changes to the home network then the MyFire Wi-Fi set up must be repeated.

Quick Reference Table - for LED.

LED INDICATOR FOR MYFIRE WI-FI BOX			
LABEL	LED		STATUS
Power	Blue	On	Power On
		Off	Power Off
WLAN	Green	On	Connected to home network (Wi-Fi Router)
		Off	Not connected to home network (Wi-Fi Router)
		Flashing	MyFire Wi-Fi Box in Access Point Mode
Receiver	Blue	On	Receiver connected
		Off	No receiver connected or connection lost
All LEDs		Flashing	Internal Configuration

It may be necessary to reset the MyFire Wi-Fi box using a paperclip or similar.  
 The table below shows the length of time required for each reset and the confirmation signals.

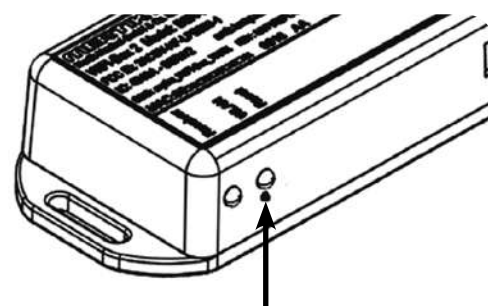

Press Reset Button	LED Status Blue Power LED	Function
1 Sec	Continuously flashes every 1/2 second	Activates Access Point Mode for 10mins (connect MyFire Wi-Fi module to home network). Simultaneously the Wi-Fi channel changes.
5 Secs	Two rapid flashes every 1 second	System Reset.
10 Secs	Flashes every 100 milliseconds (Continuous)	Restore factory firmware (MyFire Wi-Fi module will set to default after reboot); takes up to 2 minutes.
20 Secs	Flashes every 50 milliseconds (Continuous)	Restores factory firmware and erases all data not locked. (MyFire Wi-Fi module will set to default after reboot); takes up to 2 minutes.

## FLAME FAILURE DEVICE

This is a safety feature incorporated on this appliance which automatically switches off the gas supply if the pilot goes out and fails to heat the thermocouple.

**IF THIS OCCURS DO NOT ATTEMPT TO RELIGHT THE APPLIANCE FOR 3 MINUTES.**

## RUNNING IN

During initial use of a new Gazco appliance a strong odour will be encountered as various surface coatings become hot for the first time. Although these odours are harmless it is recommended that the appliance is operated on maximum for 4 to 8 hours in order to fully burn off these coatings. After this period the odours should then disappear.

If the odours persists, please contact your installer for advice.

During the first few hours of burning there may be discolouration of the flames. This will also disappear after a short period of use.

## SERVICING

The appliance must be serviced every 12 months by a qualified Gas Engineer. In all correspondence always quote the Model number and the Serial number which may be found on the Commissioning Checklist (Installation Instructions).

## INSTALLATION DETAILS

Your installer should have completed the commissioning sheet at the front of this book. This records the essential installation details of the appliance. In all correspondence always quote the Model number and Serial number.

## HOT SURFACES

Parts of this appliance become hot during normal use.

Regard all parts of the appliance as a working surface.

Provide a suitable fire guard to protect young children and the infirm.

## APPLIANCE WILL NOT LIGHT

If you cannot light the appliance:

Check and change the batteries in the remote handset.

Consult your Gazco retailer or installer if the appliance still does not light.

 = Hot Surface

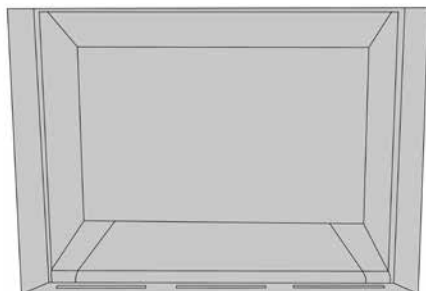

## INSTALLATION

### APPLIANCE LOCATION

This appliance is designed for studwork installations.

This appliance must not be installed in a room that contains a bath or shower.

Combustible parts of the studwork must not be any closer than the minimum dimensions shown in the diagrams. NOTE: These dimensions must be maintained even if the combustible materials is protected by non-combustible linings.

Do not pack the void around or above the appliance with insulation materials such as mineral wool.

The void into which the cassette is fitted must be ventilated to prevent a build up of heat. If the void is sealed then it will be necessary to fit vents on both sides at both low and high levels of the exposed side-face **with an open free area of 200cm<sup>2</sup> each**. These vents should take cold air from the room and return warm air back into the room.

A removable access hatch must be left in the side of the chimney breast for future servicing and inspection of the appliance.

Build the studwork chimney breast to the desired size. Ensure that the clearances to combustible materials is maintained.

### SAFETY PRECAUTIONS

For your own and other's safety, you must install this appliance according to local and national codes of practice. Failure to install the appliance correctly could lead to prosecution. **Read these instructions before installing and using this appliance.**

These instructions must be left intact with the user.

Do not attempt to burn rubbish on this appliance.

Keep all plastic bags away from young children.

Do not place any object on or near to the appliance and allow adequate clearance above the appliance.

**IF THE APPLIANCE IS EXTINGUISHED OR GOES OUT IN USE, WAIT 3 MINUTES BEFORE ATTEMPTING TO RELIGHT THE APPLIANCE.**



**IMPORTANT: REFER TO DATA BADGE AND TECHNICAL SPECIFICATION AT THE FRONT OF THE MANUAL TO ENSURE THE APPLIANCE IS CORRECTLY ADJUSTED FOR THE GAS TYPE AND CATEGORY APPLICABLE IN THE COUNTRY OF USE.**

**FOR DETAILS OF CHANGING BETWEEN GAS TYPES REFER TO SERVICING SECTION REPLACING PARTS.**

### UNPACKING

Remove the appliance from its packaging, and check that it is complete and undamaged.

Put the loose ceramic parts to one side so that they are not damaged during installation.

## FLUE & CHIMNEY REQUIREMENTS

**Note: This appliance must only be installed with the flue supplied.**

The following: must be adhered to:

The flue must be sited in accordance with BS5440: Part 1 (latest edition).

Fit a guard to protect people from any terminal less than 2 metres above any access such as level ground, a balcony or above a flat roof.

All vertical and horizontal flues must be securely fixed and fire precautions followed in accordance with local and national codes of practice.

Two types of flue terminals are available, horizontal and vertical.

To measure for a horizontal terminal decide on the terminal position.

Measure the height from the top of the appliance to the centre of the required outlet.

For minimum and maximum flue dimensions see relevant sections.

Allow enough room either above or to the side of the appliance to assemble the flue on top.

Assemble a horizontal flue in the following order:

- Vertical section
- 90° elbow
- Horizontal plus terminal

Support the opening of a masonry installation with a lintel.

Only the horizontal terminal section can be reduced in size.

## TIMBER FRAMED BUILDINGS

It will be necessary to provide additional clearance when the flue passes through a wall containing any combustible materials so as to prevent a fire hazard.

The hole through which the flue will pass, must have a steel sleeve which is positioned so that an air gap of at least 25mm is maintained between the outer surface of the flue, and any part of the sleeve.

For further guidance on the installation of gas appliances in timber framed buildings, contact your local buildings control authority.

## GAS SUPPLY

**This appliance is intended for use on a gas installation with a governed meter.**

Make sure local distribution conditions (identification of the type of gas and pressure) and the adjustment of the appliance are compatible before installation.

Ensure the gas supply delivers the required amount of gas and is in accordance with the rules in force.

Soft copper tubing can be used on the installation and soft soldered joints outside the appliance.

A factory fitted isolation device is part of the inlet connection; no further isolation device is required.

All supply gas pipes must be purged of any debris that may have entered prior to connection to the appliance.

The gas supply enters through the Silicone Panel located on the REAR-HAND side of the outer box BASE. Slit with a sharp knife prior to passing the supply pipe through.

The gas supply must be installed in a way that does not restrict the removal of the appliance for servicing and inspection.

## VENTILATION

The installation of this product requires no additional ventilation modifications to the building.

However, it will be necessary to ensure the housing for the appliance has vents provided to allow air to circulate and prevent overheating.

DIMENSIONS

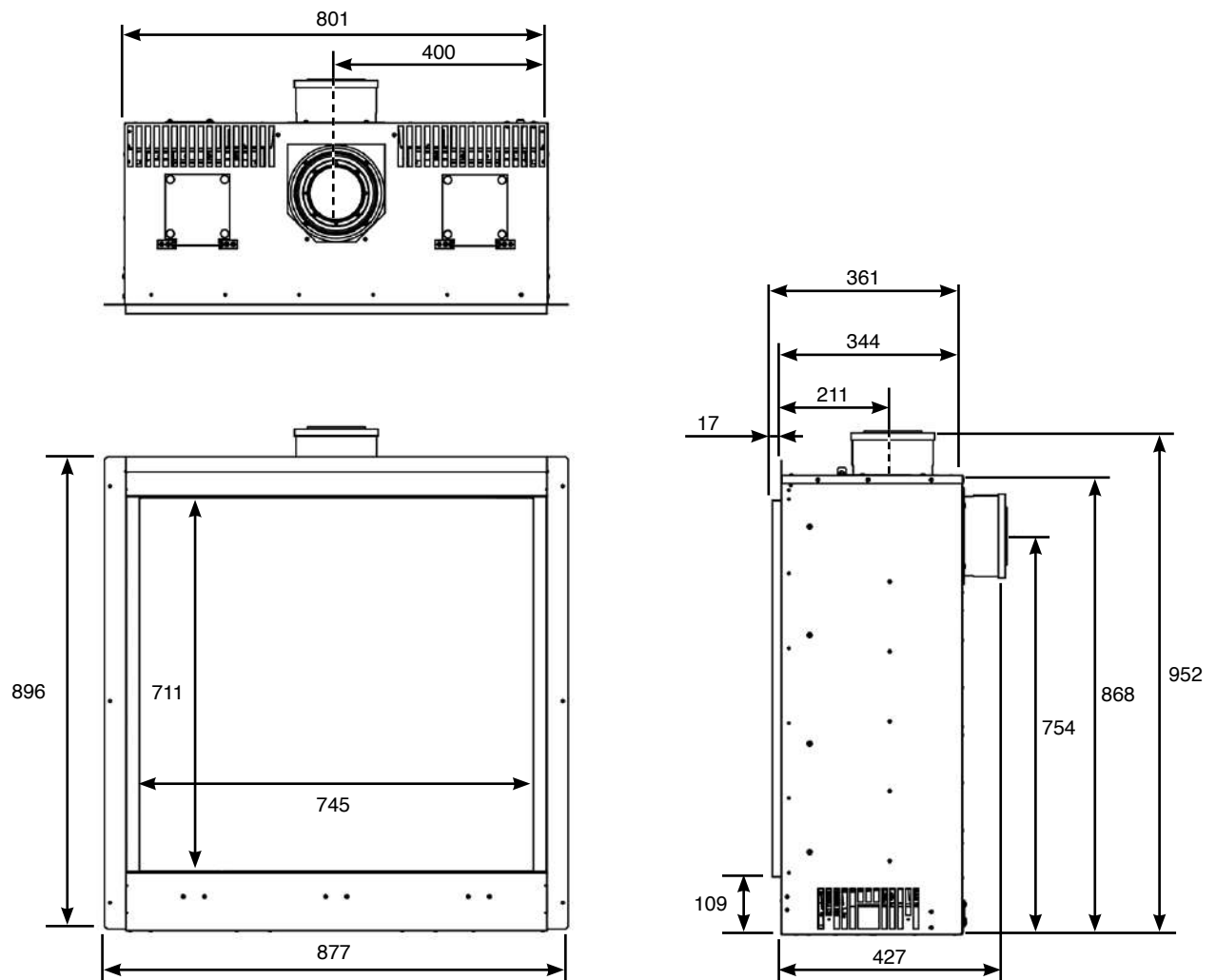

## TECHNICAL SPECIFICATION

Covering the following models:

	REFLEX 75T NAT GAS	REFLEX 75T LPG
Black Reeded	191-082	191-471
Vermiculite	191-094	191-487
Brick Effect	191-106	191-490
Ledgestone	191-111	191-512
Black Glass	191-127	191-528

MODEL	GAS CAT.	GAS TYPE	WORKING PRESSURE	GAS RATE M <sup>3</sup> /H	INPUT KW (GROSS)		COUNTRY
					HIGH	LOW	
<b>Reflex 75T</b>	I <sub>2</sub> H	Nat Gas G20	18mbar	0.953	10.0	4.1	GB, IE
<b>Reflex 75T</b>	I <sub>3+</sub>	LPG G31	37mbar	0.369	9.8	4.3	
<b>Efficiency Class 1 - 92 % / NO<sub>x</sub> Class 4</b>							
Flue Outlet Size Ø 100mm							
Flue Inlet Size Ø 152mm Ø							
Gas Inlet Connection Size Ø 8mm							

Power Supply: A 230V +/- 10% - 50Hz  
 Maximum power consumption: 9 Watts  
 Operating Temperature: 0°C - 40°C

### THIS APPLIANCE MUST BE EARTHED

A 2 metre lead with plug containing a 3 amp fuse is supplied. Only use a 3 amp fuse with this appliance.

**i** The net efficiency of this appliance has been measured as specified in EN613:2001 and the result after conversion to gross using the appropriate factor from Table E4 of SAP 2012 is NG: 82.9%/LPG: 84.7%. The test data has been certified by Kiwa Nederland BV. The gross efficiency value may be used in the UK Government's Standard Assessment Procedure (SAP) for energy rating of dwellings.

TECHNICAL SPECIFICATION

INJECTOR TABLE

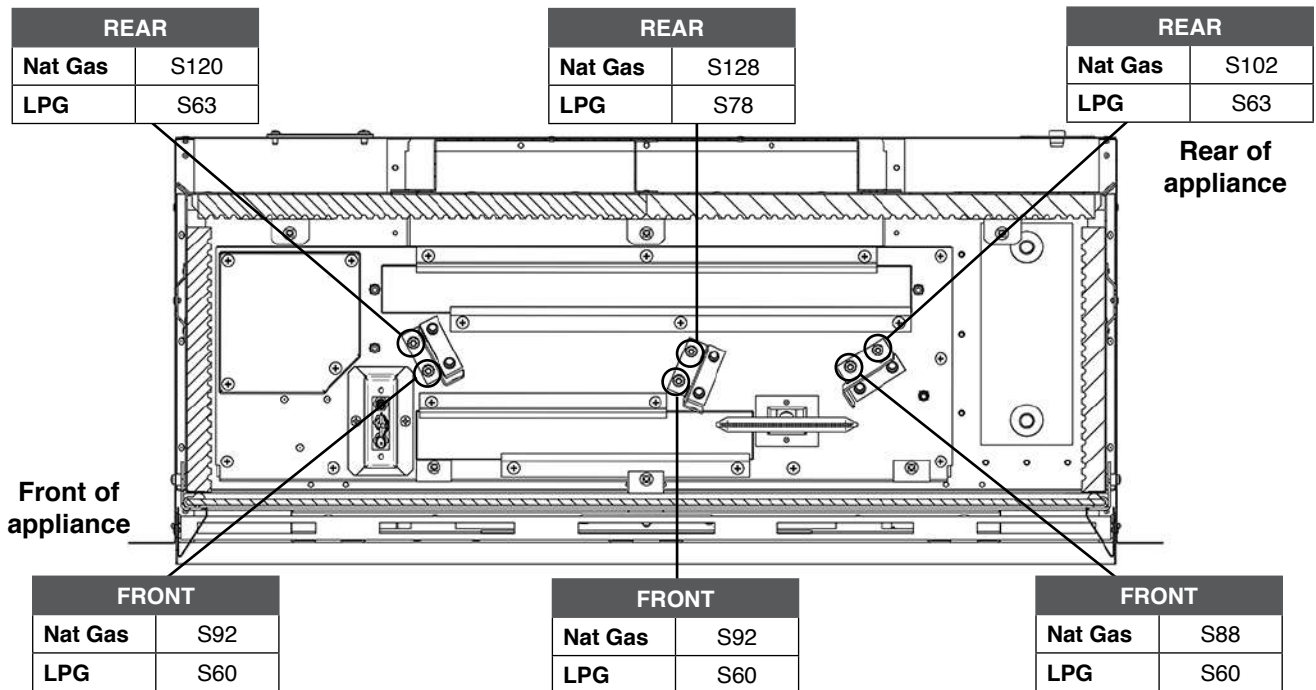

NOTE: Aeration Holes are in each leg of the burners. These holes are different sizes at the Front and Back for each individual leg.

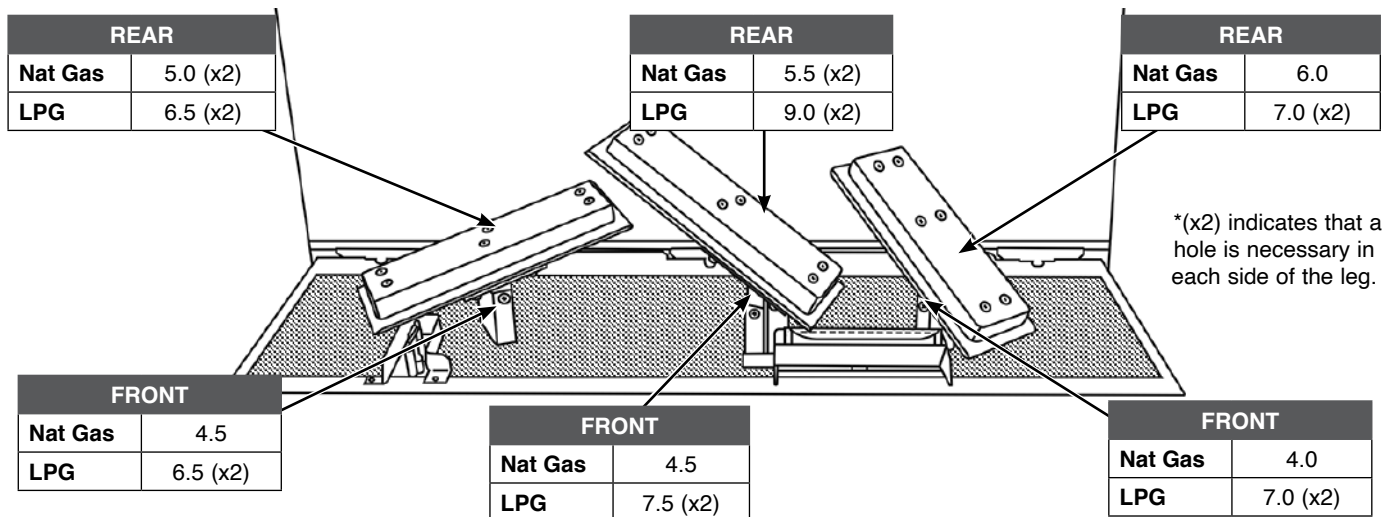

## TECHNICAL SPECIFICATION

### RESTRICTOR TABLES

RESTRICTOR REQUIREMENT - VERTICAL & HORIZONTAL FLUE SPECIFICATION		
Vertical flue height from top of appliance	Horizontal length	Restrictor size
500mm - 999mm	Up to 500mm	N/A
1000mm - 1499mm	Up to 1000mm	N/A
1500mm - 3000mm	Up to 5000mm	N/A

TOP EXIT - VERTICAL ONLY INCLUDING OFFSET (8" WITH 6" ADAPTER)	
Vertical flue height from top of appliance	Restrictor size
1500mm - 1999mm	70mm
2000mm - 4999mm	60mm
5000mm - 10000mm	52mm

This appliance has been certified for use in countries other than those stated. To install this appliance in these countries, it is essential to obtain the translated instructions and in some cases the appliance will require modification. Contact Gazco for further information.

### PACKING CHECKLIST

QTY. DESCRIPTION	FIXING KIT CONTAINING
1 x Cassette and burner assembly	1 x Instruction manual
1 x Set of lining panels	6 x Woodscrews
1 x Log set (5 logs)	6 x Wall plugs
2 x Large Embers	1 x Self adhesive foam strip
1 x Pilot Ember	1 x Handset
2 x Small Embers	2 x AAA cell batteries
1 x Shale Effect pack	
1 x Amber Effect pack	



WIRING DIAGRAM

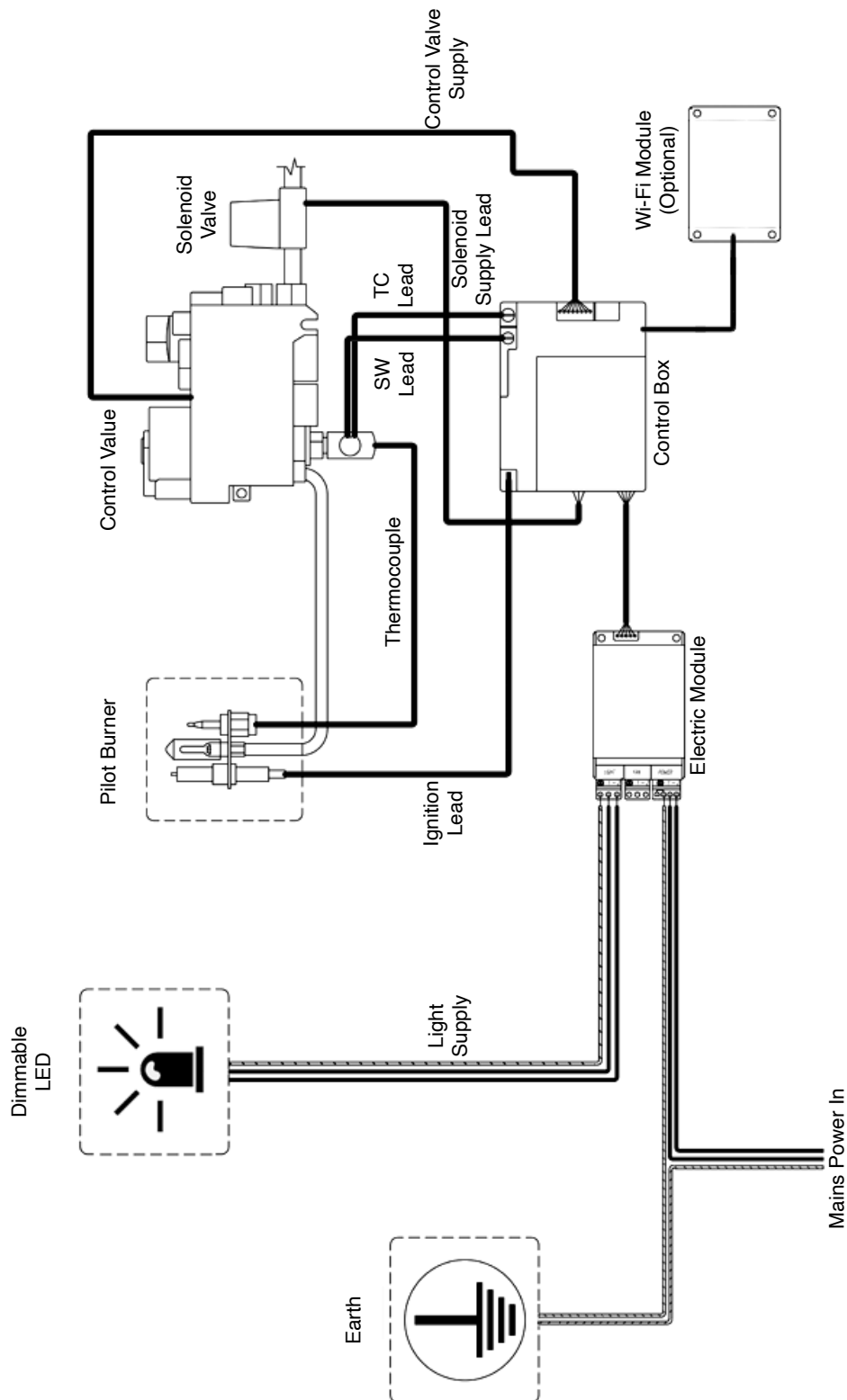

## FLUE OPTIONS

### REAR FLUE

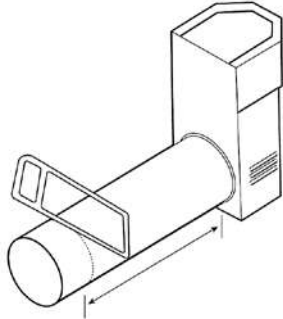

Terminal dimensions:  
395 x 200 x 200 mm (H x W x D)  
Guard supplied  
Cut to length as required on site.



**IMPORTANT: REAR FLUE INSTALLATION**  
When fitting the appliance with a rear flue terminal it is essential to observe distances to combustible material when flue passes through a combustible wall. Ensure the terminal is suitable protected if fitting to an external combustible structure. There is a fixing kit available from Gazco (Part No 999-220). **DO NOT INSTALL DIRECTLY ONTO A COMBUSTIBLE SURFACE.**

Decide on the terminal position.

Measure the height from the finished hearth level/ base of the appliance to the centre of the required hole.

A masonry installation requires the addition of a suitable lintel to support the opening. Refer to Installation Instructions, Technical Information for details of the flue length.

NOTE - Carefully consider:

- Terminal positions
- Flue supports
- Weatherproofing
- Fire precautions

For all the above options, you must conform to local and national codes of practice.

Use only Gazco supplied flue on this appliance.

A guard (supplied) must be fitted to any terminal less than 2 metres above any access such as level ground, a balcony or above a flat roof.

### TIMBER FRAMED BUILDINGS

It will be necessary to provide additional clearance when the flue passes through a wall containing any combustible materials so as to prevent a fire hazard.

The hole through which the flue will pass, must have a steel sleeve which is positioned so that an air gap of at least 25mm is maintained between the outer surface of the flue, and any part of the sleeve.

For further guidance on the installation of gas appliances in timber framed buildings, contact your local buildings control authority.

### TOP EXIT FLUE

### TOP FLUE UP AND OUT KIT (8523)

Vertical from the top of the appliance then horizontally out, see Diagram 3. The basic kit comprises:

- 1 x 500mm terminal length
- 1 x 90 degree elbow
- 1 x 500mm vertical length
- 1 x wall plate
- 1 x 60mm restrictor
- 1 x 75mm restrictor
- 4 x fixing screw

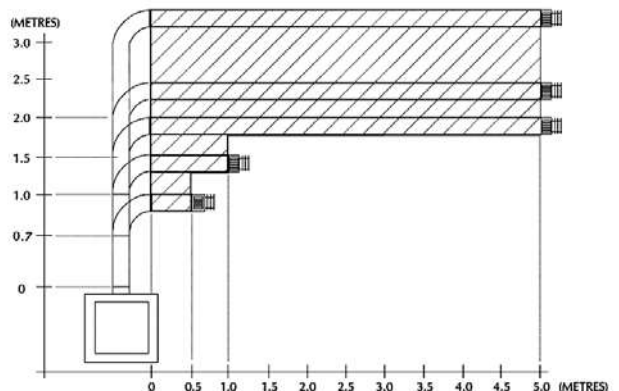

Start of bend to centre line of horizontal flue 170mm. Centre line of vertical flue to end of bend 220mm.

This kit provides the minimum materials. Extra lengths can be added to the vertical and horizontal sections.

Refer to Installation Instructions, Technical Specification on page 17 to identify when to use a restrictor.

## FLUE OPTIONS

### TOP FLUE UP AND OUT WITH ADDITIONAL BEND

Any additional bend may be used on the horizontal section (either 45° or 90°), but the overall horizontal flue run will be reduced.

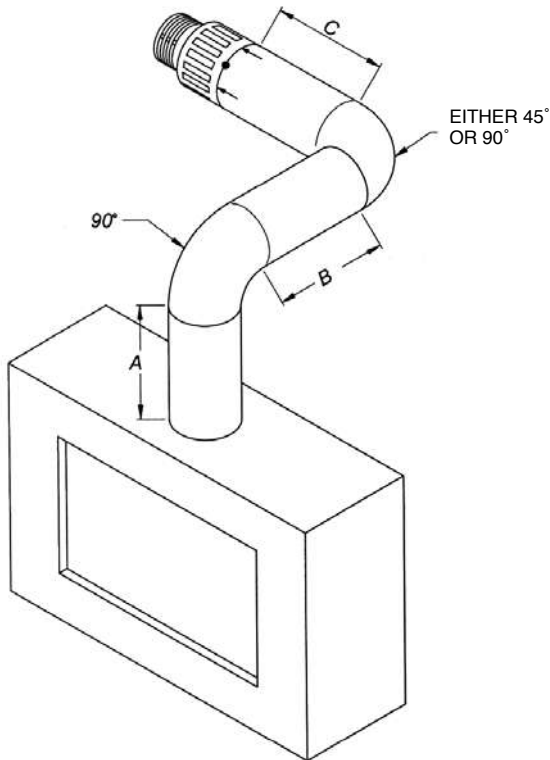

When A = 1.0 to 1.499 metres B + C = 1.0 metres maximum  
 When A = 1.499 metres to 3.0 metres B + C = 4.0 metres maximum

### TOP FLUE VERTICAL KIT (8524)

This flue is vertical from the top of the appliance. A minimum vertical rise of 1.5m (4'9") to a maximum of 10m (32'10").

The basic kit comprises:

- 2 x 1m lengths
- 1 x 1m terminal lengths
- 1 x 52mm restrictor
- 1 x 47mm restrictor
- 1 x 60mm restrictor
- 1 x 70mm restrictor

Extra lengths may be added from the table.

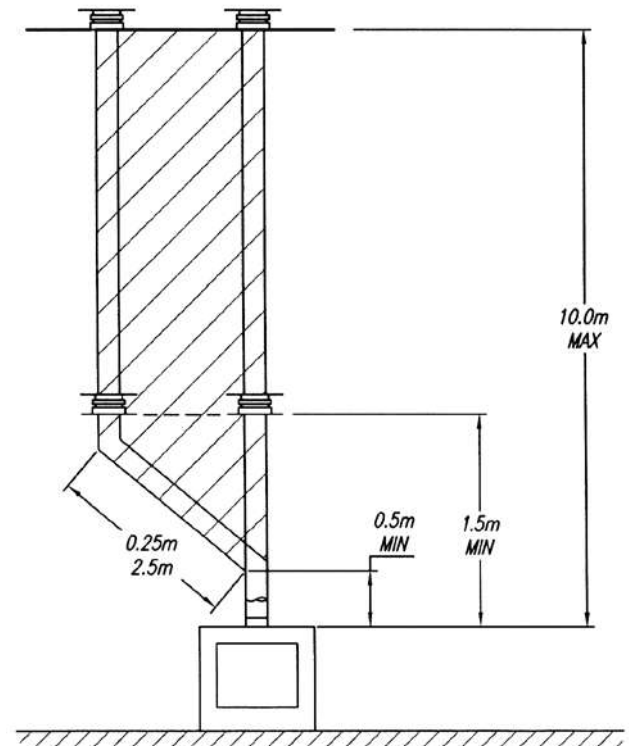

### TOP FLUE VERTICAL OFFSET KIT (8530/8530AN)

Used with kit 8524. A minimum rise of 500mm is required to the first bend.

## FLUE OPTIONS

### OPTIONAL EXTRA FLUE LENGTHS AND BENDS

All flue components are 150mm diameter (6")

NOMINAL LENGTH	ACTUAL LENGTH	STAINLESS FINISH	ANTHRACITE FINISH
200mm*	140mm*	8527	8527AN
500mm*	440mm*	8528	8528AN
1000mm*	940mm*	8529	8529AN

\*Not including adapter dimensions

**NOTE:** The following areas need careful consideration.

- a) Terminal positions
- b) Flue supports
- c) Weatherproofing
- d) Fire precautions

For all the above options, local and national codes of practice must be adhered to.



**IMPORTANT:**  
1M VERTICAL, TERMINAL AND STRAIGHT FLUE LENGTHS MUST NOT BE CUT!

### CHIMNEY RENOVATION KIT (928-315)

Details of the Chimney Renovation Kit are available in the separate installation instructions - PR2073 Chimney Renovation Kit instructions.

## SITE REQUIREMENTS

**i** If fitting this appliance with a decorative frame it cannot be installed with the base of the appliance less than 150mm from the floor level. The frame requires a minimum clearance to allow air to circulate.

If this appliance is fitted less than 225mm from the floor, then it will require a hearth to protect the floor. The hearth should have a minimum dimension of 12mm thick, projecting 225mm in front and 150mm either side of the appliance.

The minimum opening dimensions are shown in Diagram 6.

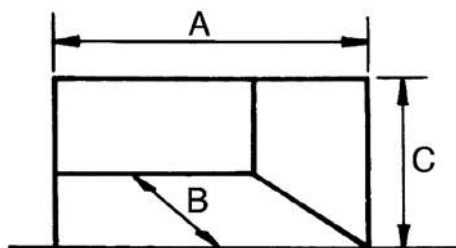

**NOTE:** If using natural materials for the back panel of the fireplace, it is recommended that it is constructed from three or more sections to prevent cracking. Resin based materials may not be suitable. This appliance is an effective heat producer and attention must be paid to the construction and finish of the fireplace.

This appliance is not suitable for installation onto a combustible wall; all combustible materials must be removed from the area shown.

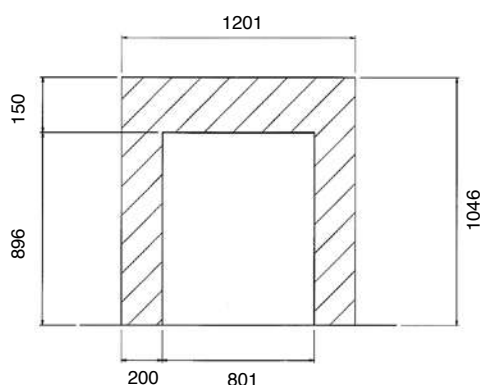

### Mantels, Hearths & Slips

**i** If fitting this appliance with a decorative surround it will be necessary to install the appliance with a hearth and Slip set.

The hearth must have a minimum depth of 225mm. It is essential to ensure that a height of 123mm is maintained from the finished floor to the bottom edge of the viewing area.

Read these instructions in conjunction with the manual supplied before installation.

## STUDWORK INSTALLATION

Combustible parts of the studwork must not be any closer than the minimum dimensions shown in the diagrams. **NOTE:** These dimensions must be maintained even if the combustible materials is protected by non-combustible linings.

Build the studwork chimney breast to the desired size. Ensure that the clearances to combustible materials is maintained.

A combustible shelf must be:

- Maximum 150mm in depth.
- Minimum 150mm high above the appliance.

A combustible side wall must be a minimum of 200mm from the appliance.

**PROTECT THE NEAREST STUDWORK WITH NON-COMBUSTIBLE MATERIAL AND MAINTAIN THESE DIMENSIONS AT ALL TIMES, SEE DIAGRAM 8.**

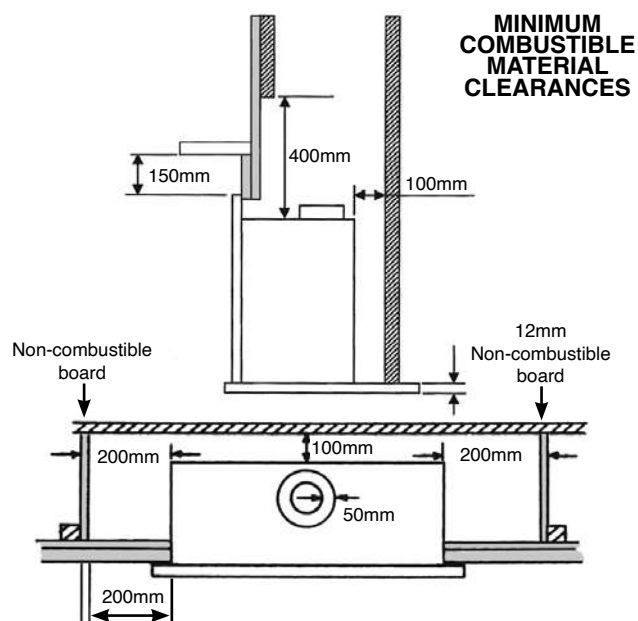

### DISTANCE TO NON-COMBUSTIBLE OR COMBUSTIBLE MATERIAL

**TO CREATE ENOUGH CLEARANCE FOR THE TOP VENTS IT IS IMPORTANT THAT NO PART OF THE STUDWORK (COMBUSTIBLE OR NOT) IS BUILT ABOVE THE TOP OF THE BOX.**

**NOTE: DO NOT ENCLOSE THE TOP OF THE VOID. THE VOID MUST EXTEND TO THE CEILING.**

It is recommended that a marble slip or similar material is used when fitting cassette fireplaces into a plastered surface, in order to allow for heat dissipation. Also allow adequate time for newly plastered areas to dry out. Rapid drying can create cracks. If in doubt, seek the advice of a professional plasterer.

## SITE REQUIREMENTS

### MASONRY INSTALLATION

Please note this appliance has been primarily designed for studwork applications. However, there are circumstances where the appliance could be installed in a block or brickwork fireplace using different methods and materials for the final effect.

**THIS VOID MUST BE VENTED TO PREVENT HEAT BUILD UP AROUND THE APPLIANCE.**

This appliance is not suitable for installation onto a combustible wall. Remove all combustible material from the area shown.

Create a Builders Opening in chimney breast to the required size, see Diagram 9. Ensure that the clearances to combustible materials is maintained.

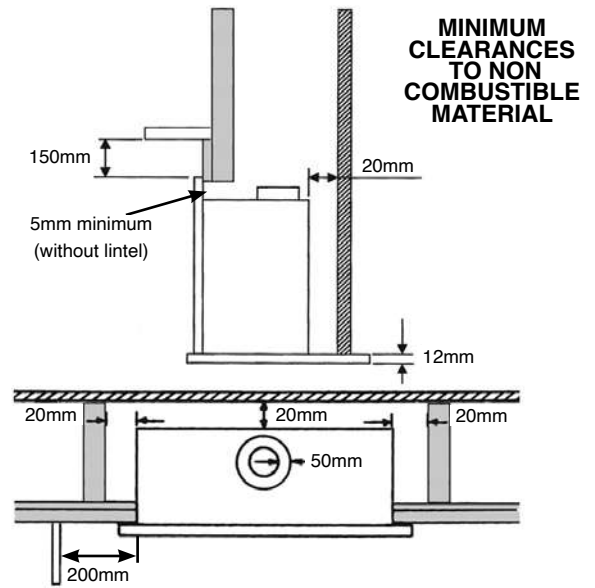

### IDEAL MASONRY INSTALLATION WITH FLUE RENOVATION KIT

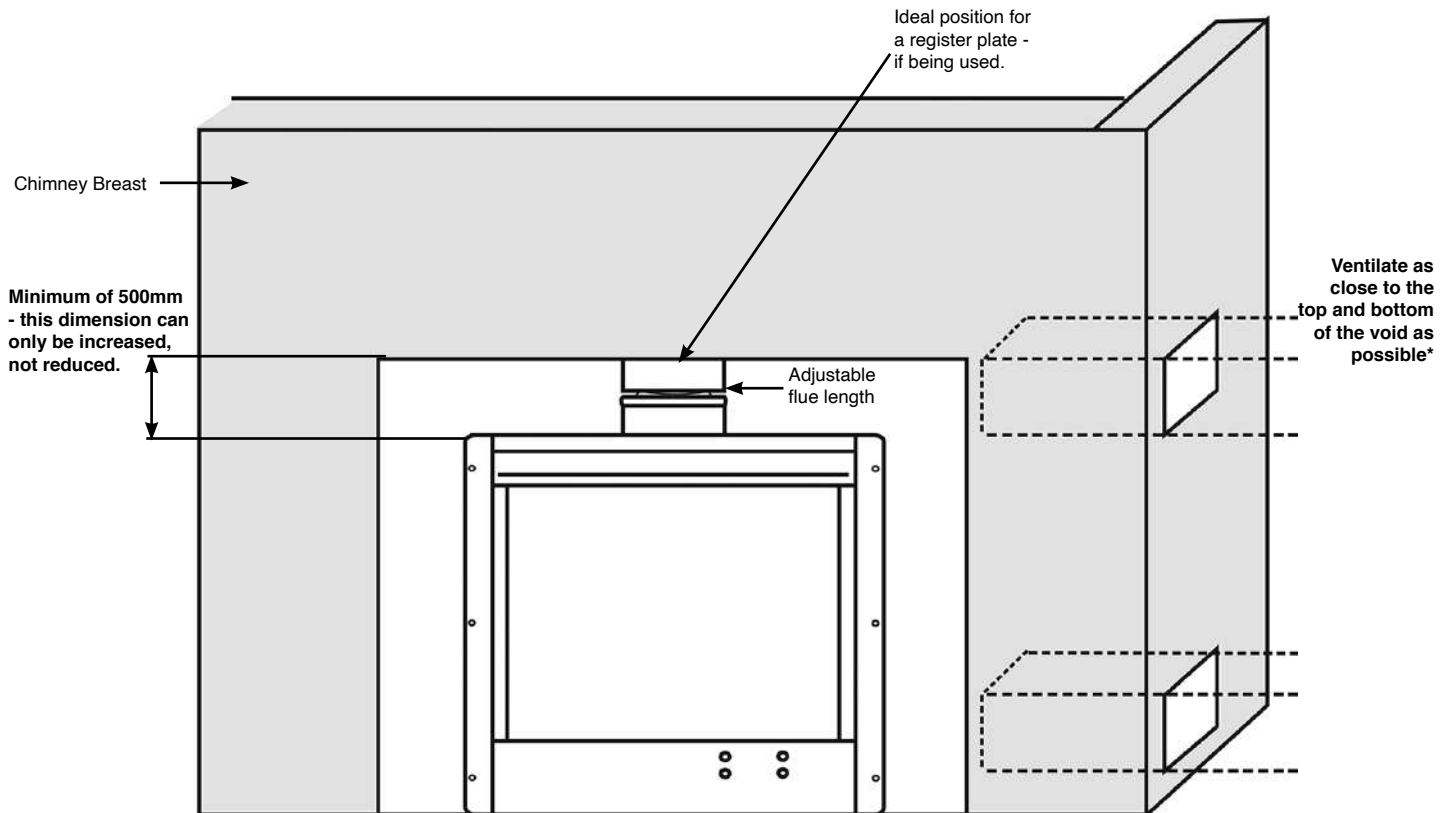

**\*BOTH SIDES MUST BE VENTILATED**

PRE-INSTALLATION

REMOVING THE GLASS

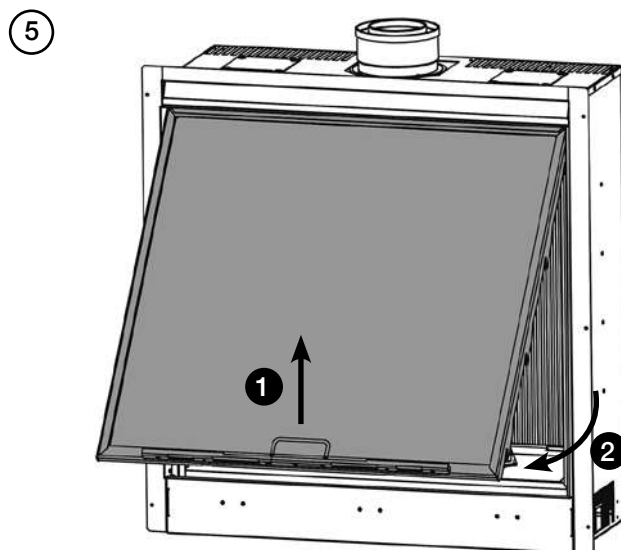
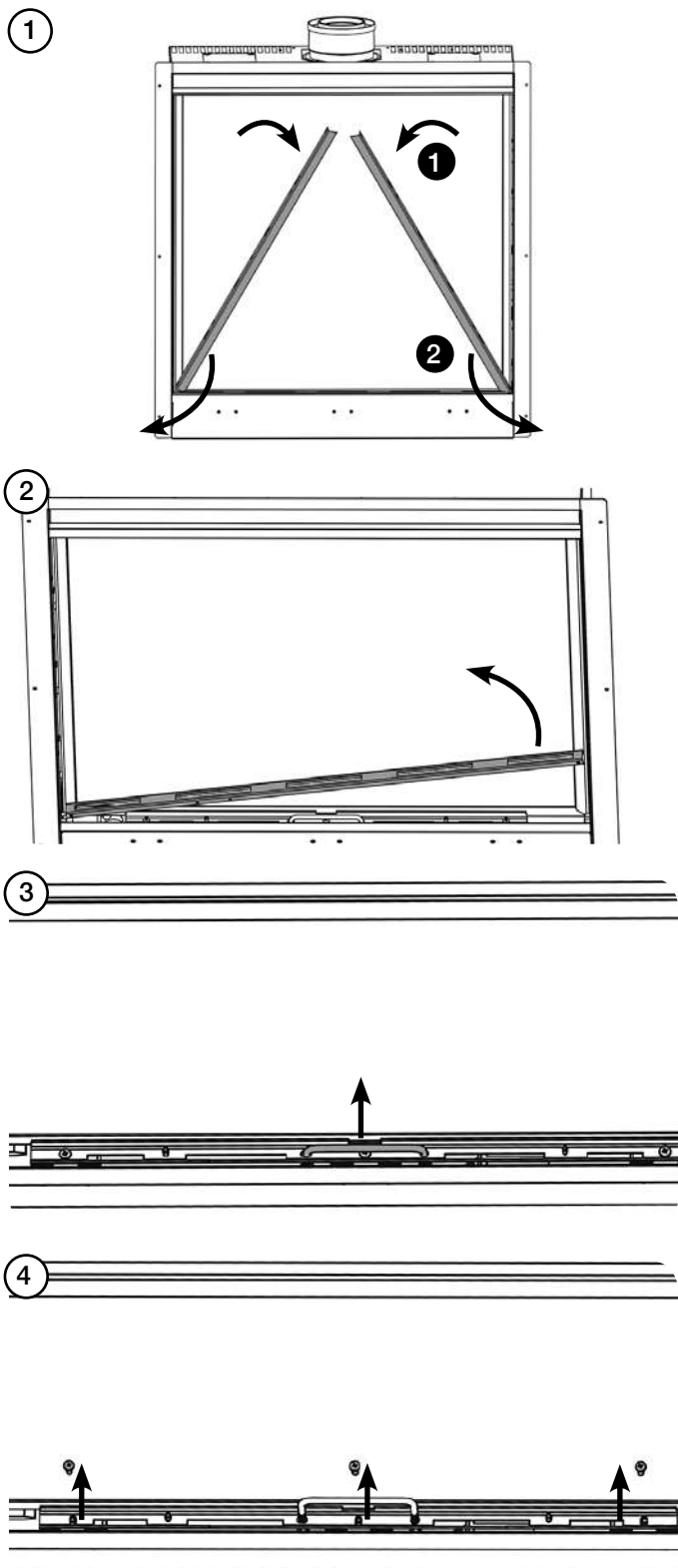

Remove the 2 boxes from the appliance and store safely as they contain the Log Burners and fuel effects.

REMOVING THE MAIN CONTROL ASSEMBLY

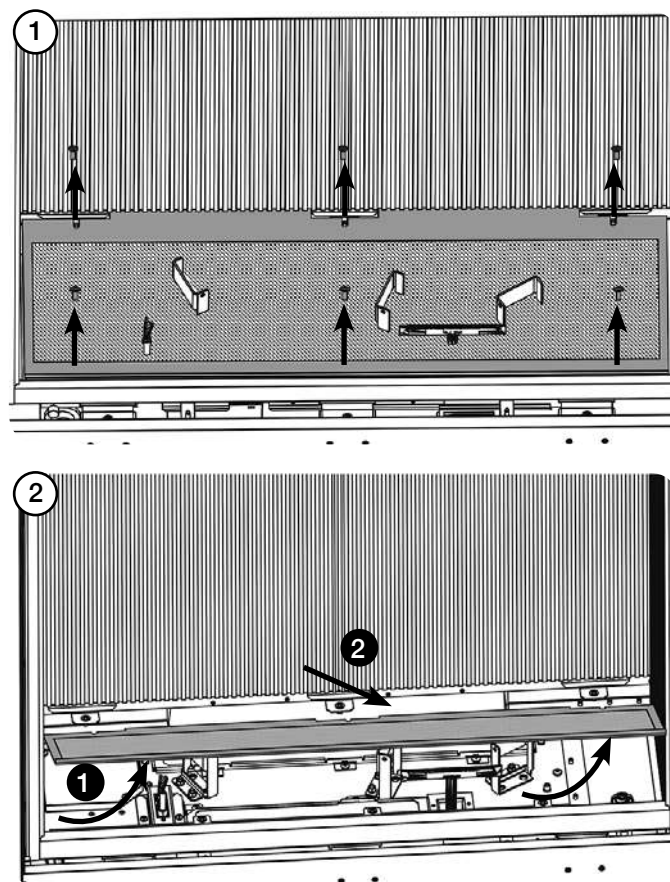



PRE-INSTALLATION

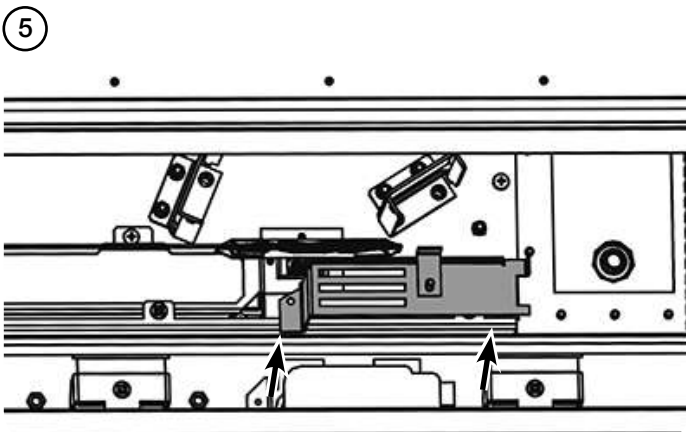
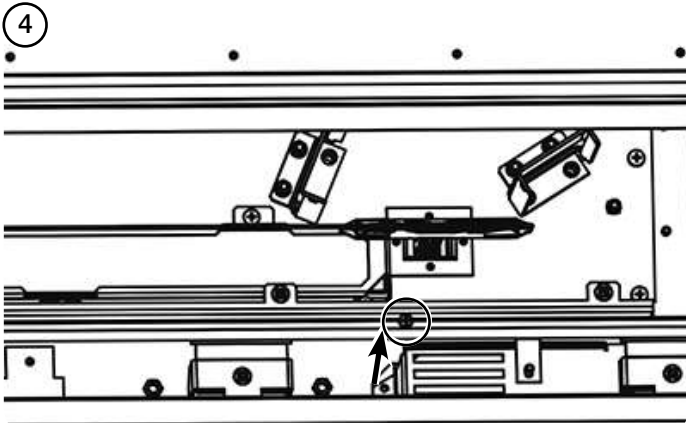
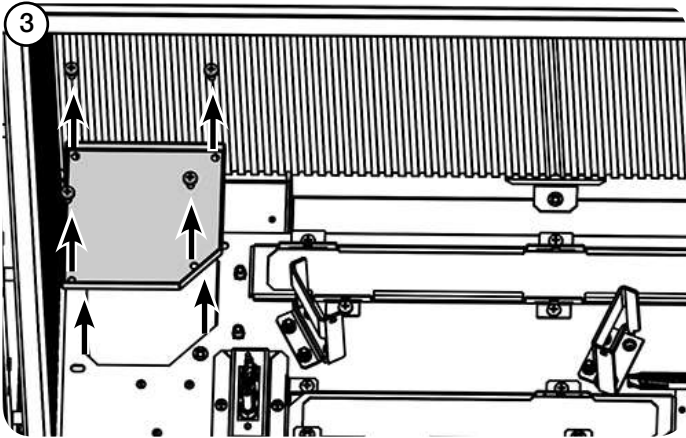

Disconnect the Mains Lead Plug, the LED leads and the receiver lead from the Module and the Wi-Fi box (if installed).  
**DO NOT REMOVE THE WIRES FROM THE PLUG.**

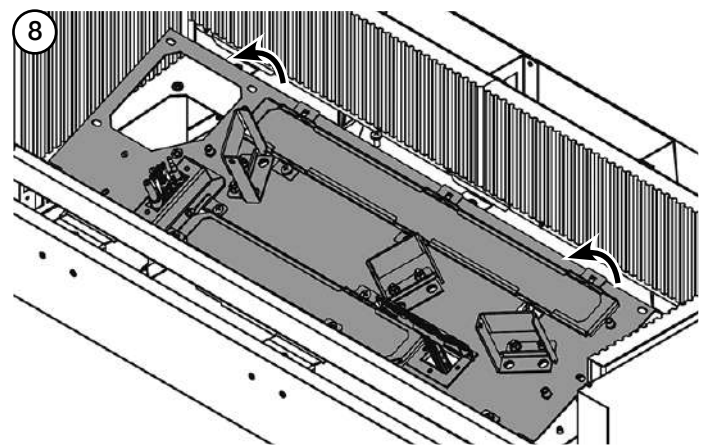
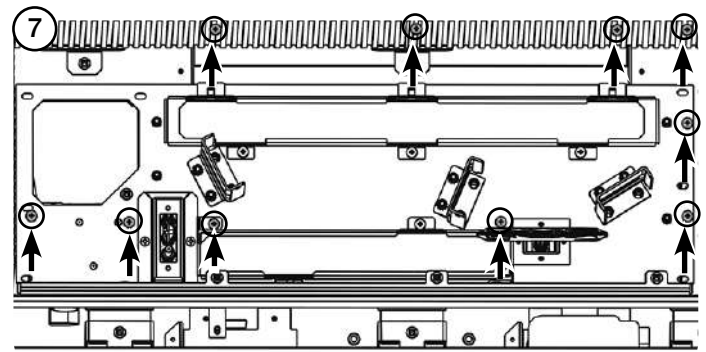
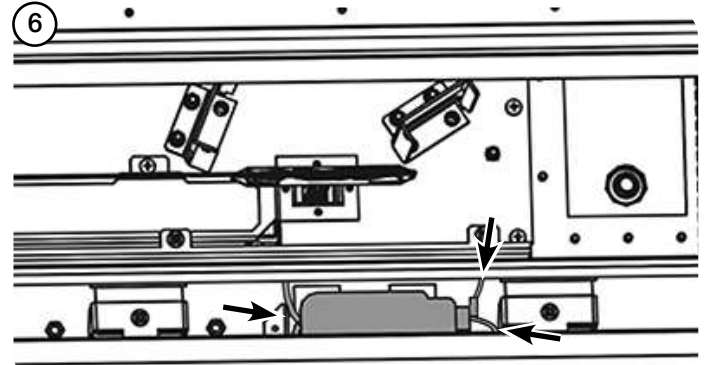



PRE-INSTALLATION

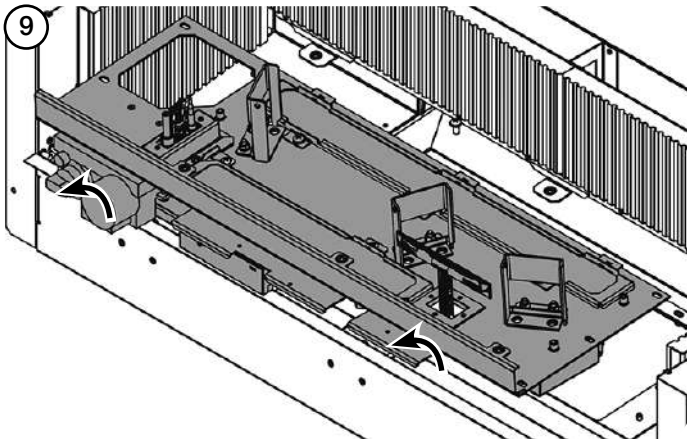

**i** **NOTE:** Take care not to catch any loose wiring previously disconnected against the front edge of the firebox.

The gas supply enters through the Silicone Panel located on the left-hand rear of the outer box; this will need to be slit with a sharp knife prior to passing the supply pipe through.

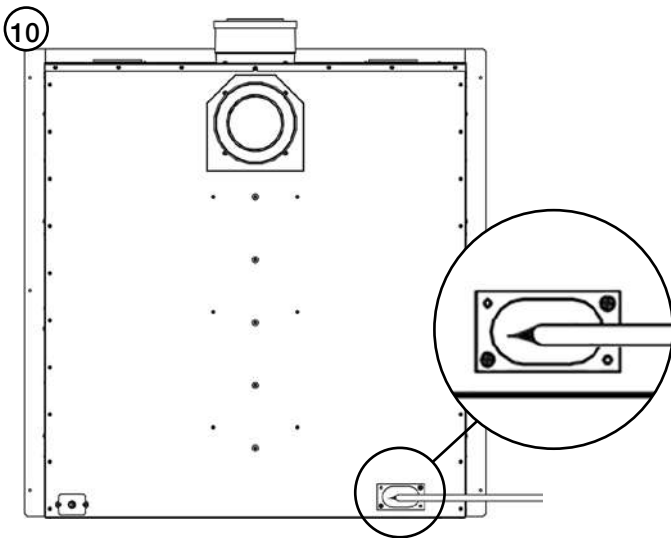

**i** **Note:** The Isolation Elbow needs to be attached to the gas pipe before installation.

## FLUE ASSEMBLY

**TAKE CARE WHEN MARKING OUT FOR THE FLUE AS IT IS DIFFICULT TO MOVE AFTER INSTALLATION. IF A RESTRICTOR IS REQUIRED FIT THIS BETWEEN THE SMALL OUTLET SPIGOT AND THE AIR DUCT. REFER TO TECHNICAL SPECIFICATIONS FOR RESTRICTOR SIZE.**

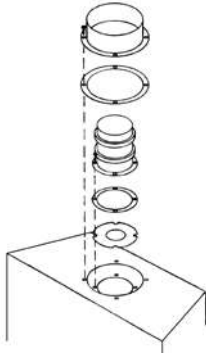

A 203mm (8") diameter hole in the wall is required to install the flue. This can be achieved by using either:

- a) Core drill
- b) Hammer and chisel

Drill small holes around the circumference when using method b). Make good both ends of the hole.

Allow enough room either above or to the side of the appliance to assemble the flue on top.

Assemble a horizontal flue in the following order:

- Vertical section
- 90° elbow
- Horizontal plus terminal

Only the horizontal terminal section can be reduced in size.

To find the length:

Measure from the outside of the wall to the stop on the 90° elbow.

**Add 10mm to the outlet end.**

Measure from the edge of the slots closest to the wall.

Mark around the flue.

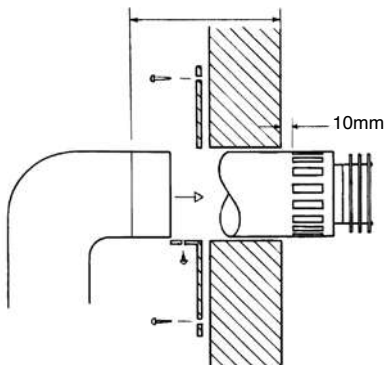

Bend the tab to 90°.

Assemble the plate onto the flue but do not secure to wall until the flue is fully assembled.

The cardboard fitment in the terminal is used to support the flue whilst it is cut to length. **ONCE CUT TO SIZE REMOVE THE CARDBOARD REMNANT.**

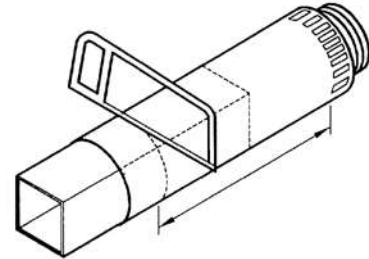

## MASONRY INSTALLATION

There are 2 methods of installation into a masonry chimney:

Edge finish Installation.

Installation with a decorative front.

Carefully read the relevant section for the installation method required.

This appliance is designed so that non-combustible board can be taken right up to the edge of the flange.

**i** It is necessary to be able to disconnect the appliance from the mains electrical supply after installation. This may be achieved by an accessible plug or by incorporating a switch into the fixed wiring in accordance with the rules in force.

### EDGE FINISH INSTALLATION

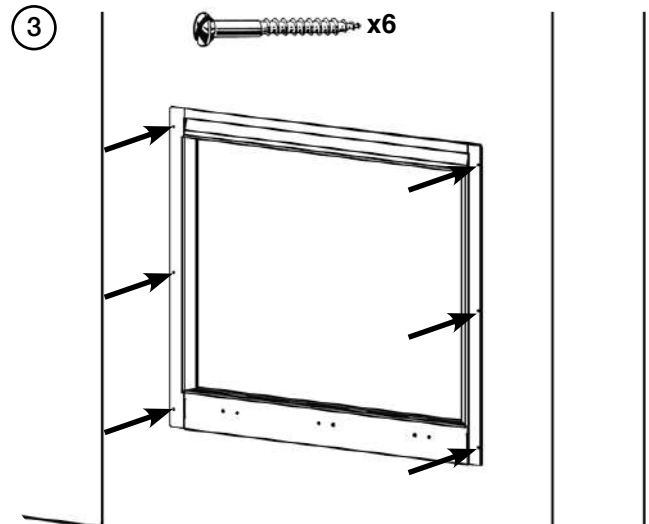
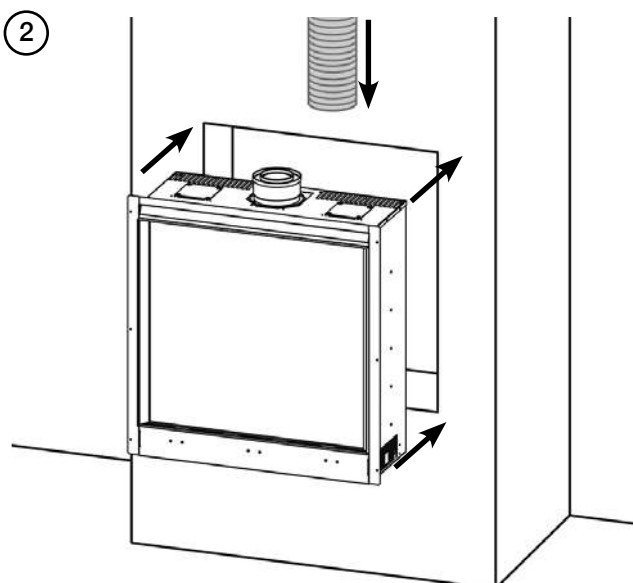
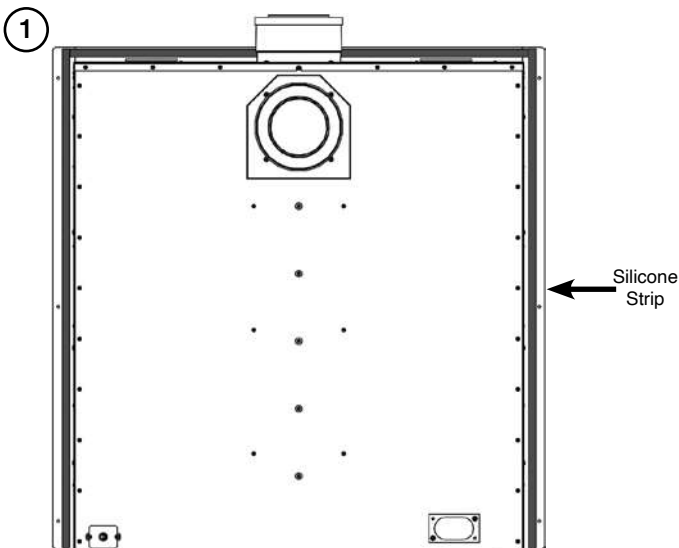

Fit non-combustible board to the chimney breast around the appliance, using the distance to combustibles detailed

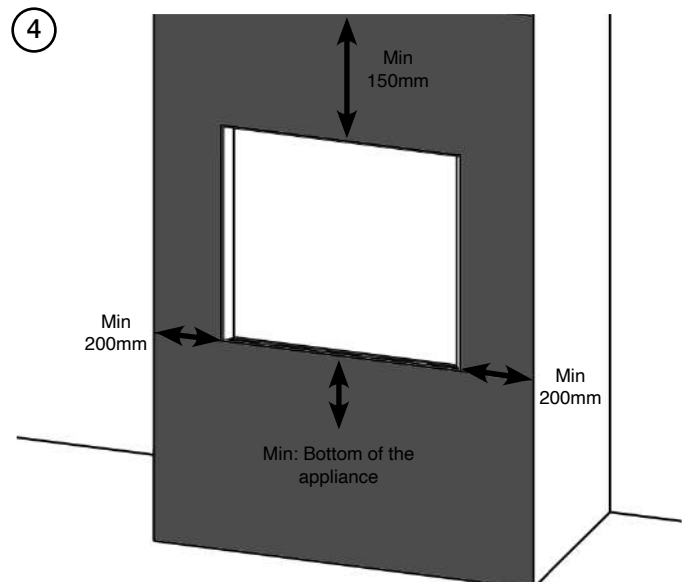

Fit plasterboard to the remaining of the chimney breast front.

Apply a heat resistant plaster around the appliance using the distance to combustibles detailed.

Apply a plaster finish to remaining chimney breast front.

MASONRY INSTALLATION

DECORATIVE FRAME INSTALLATION

**i** **Mantels, Hearths & Slips**

If fitting this appliance with a decorative surround it will be necessary to install the appliance with a **Hearth and Slip set**.  
 The hearth must have a minimum depth of 225mm. It is essential to ensure that a height of 123mm is maintained from the finished floor to the bottom edge of the viewing area.

Read these instructions in conjunction with the manual supplied before installation.

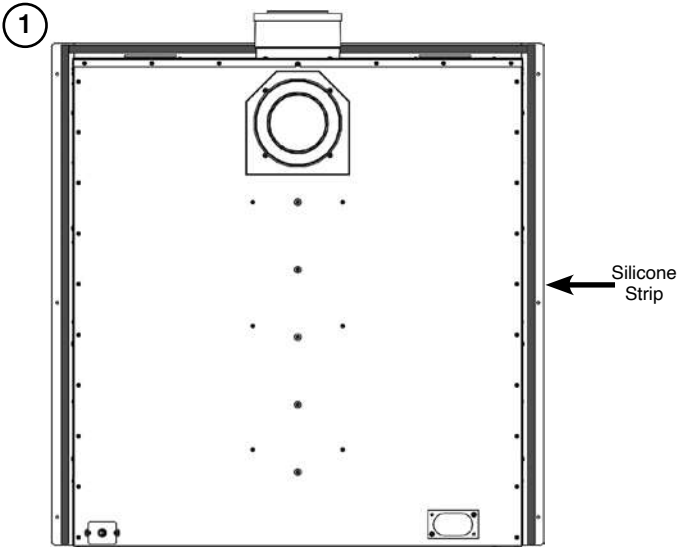

The appliance flange should sit flush to the brickwork and the edge should sit proud of the wall.

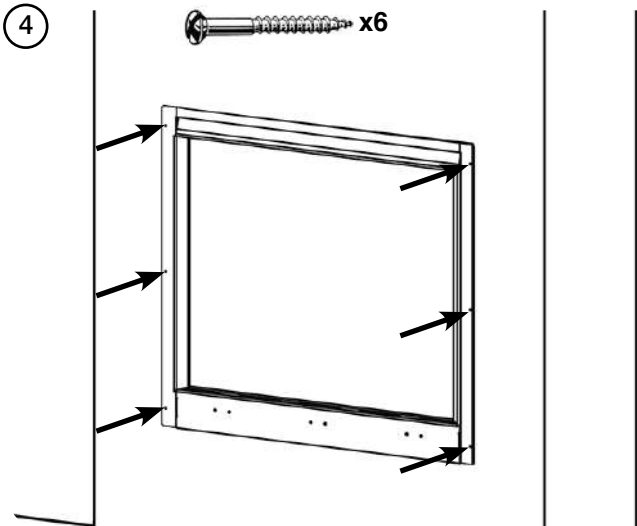
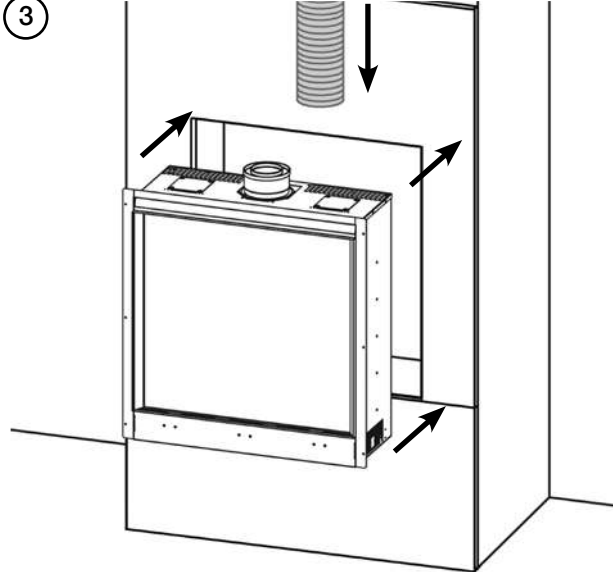
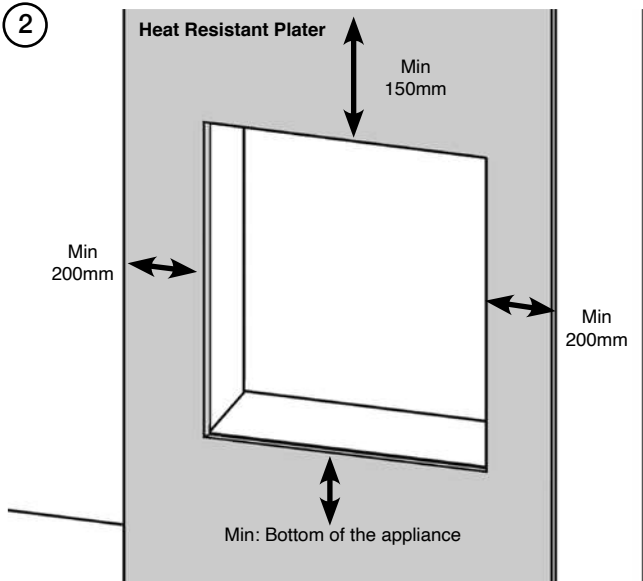

The subframe for the decorative front can now be fitted by following the instructions supplied with the Front.

**i** **NOTE: THE SUBFRAME MUST SIT FLUSH TO THE WALL LEVEL WITH THE APPLIANCE FLANGE.**

## STUDWORK ENCLOSURE CONSTRUCTION

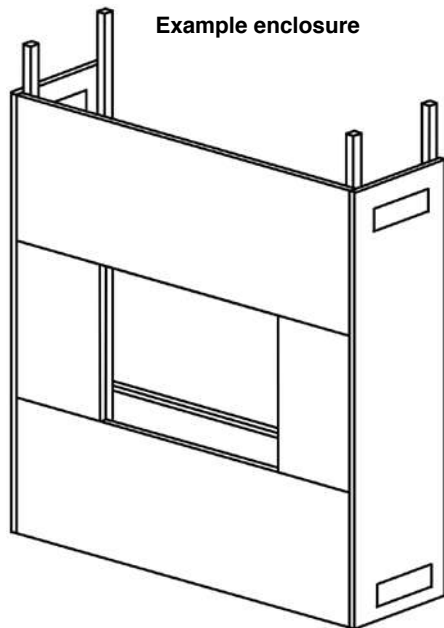

### VENTILATION



The void into which the cassette is fitted must be ventilated to prevent a build up of heat. If the void is sealed then it will be necessary to fit high and low level vents on both sides of the enclosure with a minimum vent size of 200cm<sup>2</sup> open free area each. These vents should take cold air from the room and return warm air back into the room.

Gazco recommend building the enclosure from the following materials:

Metal Studwork

Non-combustible board:

Masterboard or Promafour - NOT PINK BOARD

Heat Resistant Plaster: Purimacho (any spider cracks that develop after installation will need to be rubbed down and refilled with Purimacho heat resistant filler to stabilise).

Ensure all distances to combustible materials are maintained



It is necessary to be able to disconnect the appliance from the mains electrical supply after installation.

This may be achieved by an accessible plug or by incorporating a switch into the fixed wiring in accordance with the rules in force.

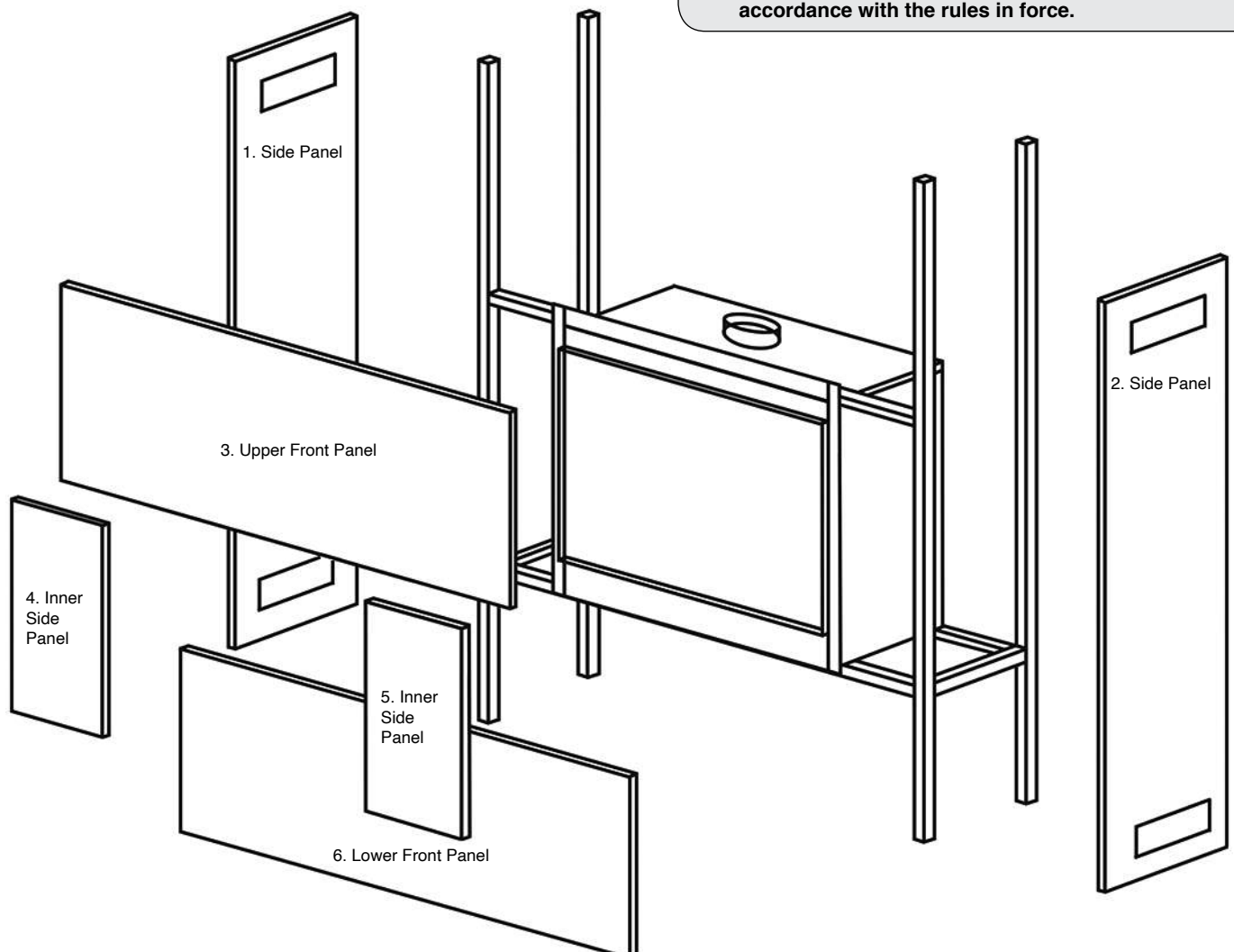

## CUTTING TEMPLATES

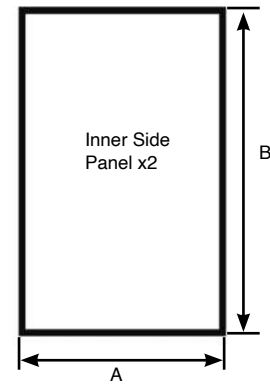
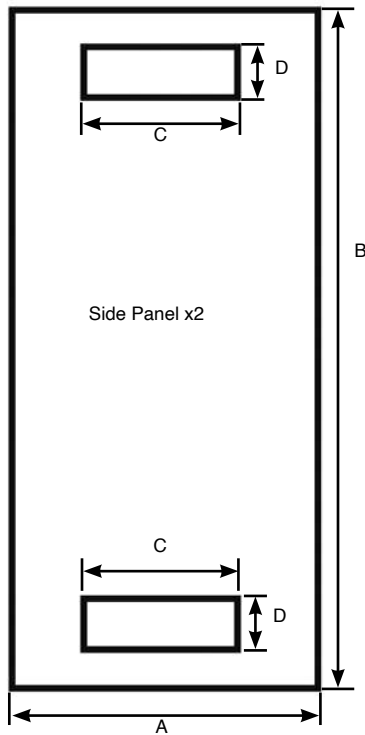
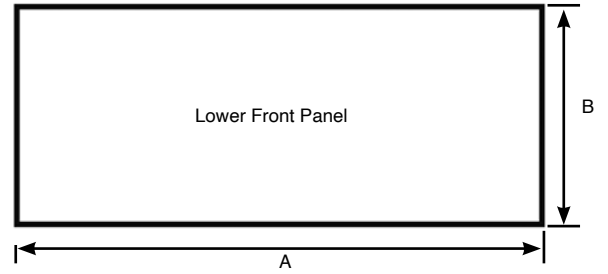
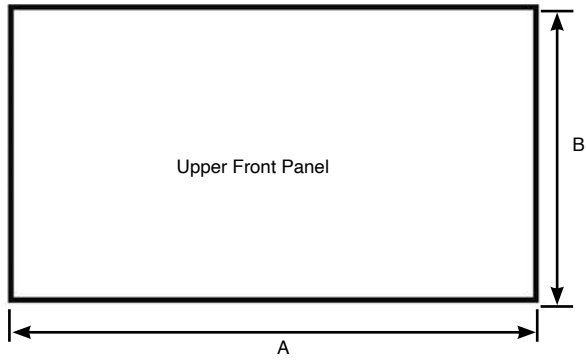

PANEL	A (MIN)	B (MIN)	C	D
Upper Front Panel	949mm	400mm	-	-
Lower Front Panel	949mm	129mm No Frame 150mm - Decorative Frame	-	-
Side Panel	404mm	901mm No Frame 940mm - Decorative Frame	100	30
Inner Side Panel	150mm	370mm	-	-

## EDGE FRAME INSTALLATION

①

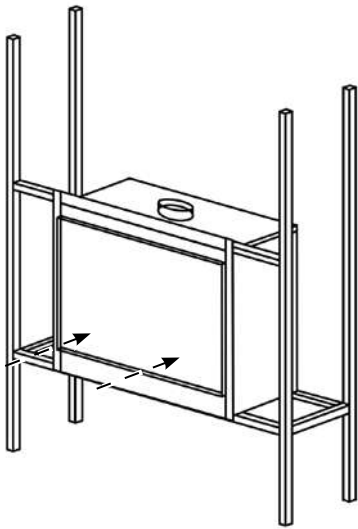

④

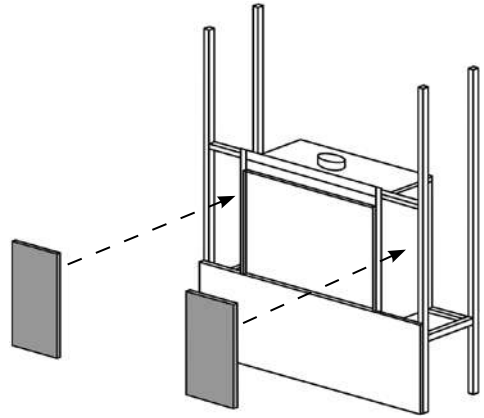

②

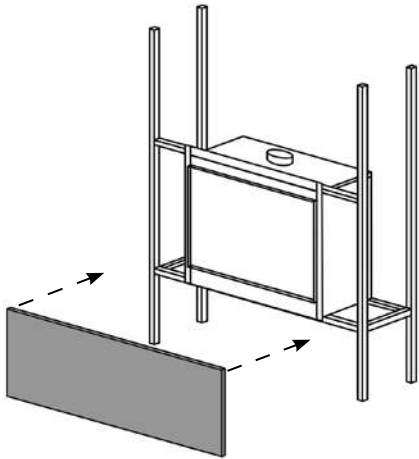

⑤

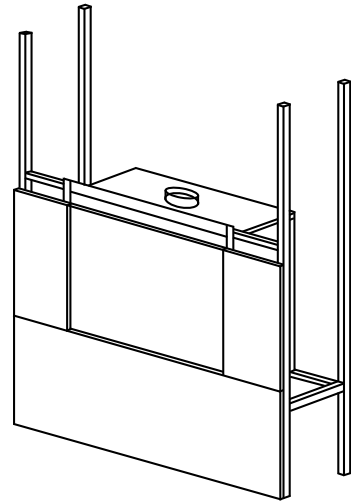

③

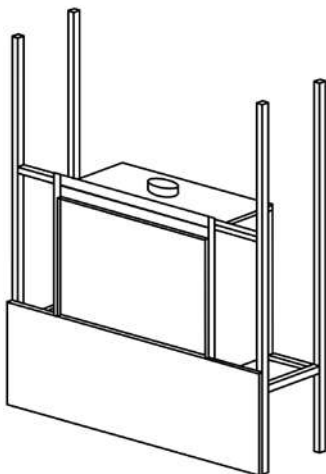

⑥

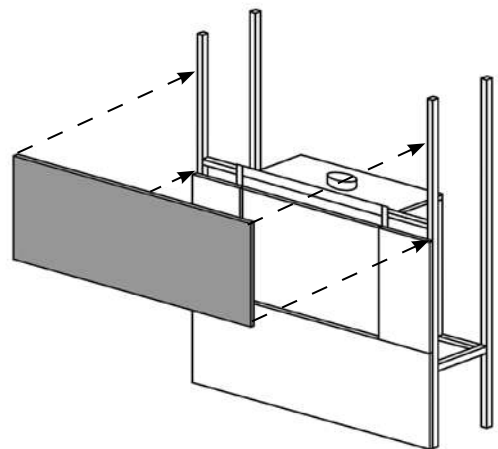

EDGE FRAME INSTALLATION

7

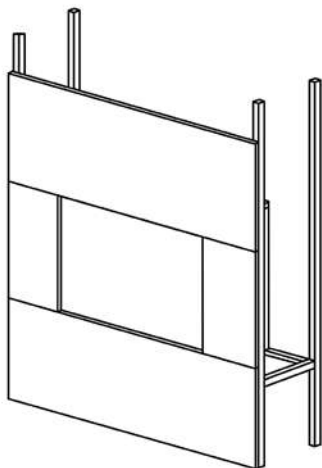

8

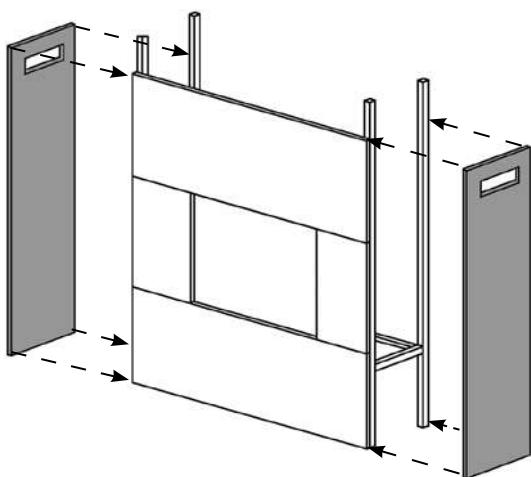

9

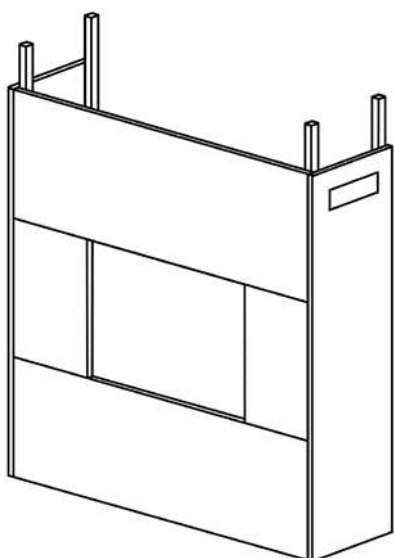



## DECORATIVE FRAME STUDWORK INSTALLATION



**IMPORTANT: BEFORE THE INSTALLATION OF THE DECORATIVE FRONT ENSURE THAT THE WALL ABOVE AND TO THE SIDES OF THE APPLIANCE IS SUITABLY CONSTRUCTED FOR THE FIXINGS TO SUPPORT THE WEIGHT OF THE FRONT. IF THE WALL IS CONSTRUCTED FROM PLASTERBOARD OR SIMILAR, IT IS ESSENTIAL THAT BATTERNS ARE LOCATED TO THE SIDES OF THE APPLIANCE IN THE FIXING AREA TO PROVIDE STRENGTH TO THE FIXINGS.**

When constructing a studwork installation it is essential to observe the clearances to combustibles but make provision for the frame fixings.

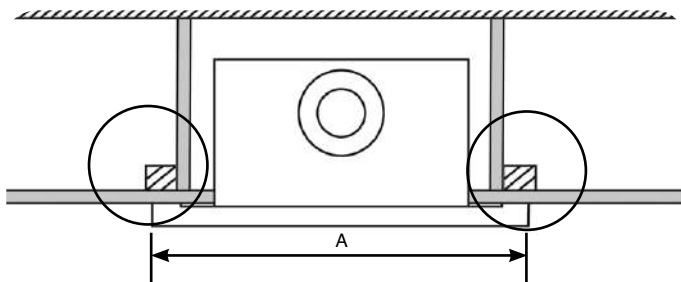

This diagram shows the minimum clearance position when installing the appliance into studwork - it is vital to ensure the opening is wide enough to accommodate the fixings for the front.

Distance between front fixings:

FRAME OPTION	A
<b>Verve XS</b>	759
<b>Icon XS</b>	759
<b>Designio2</b>	755

①

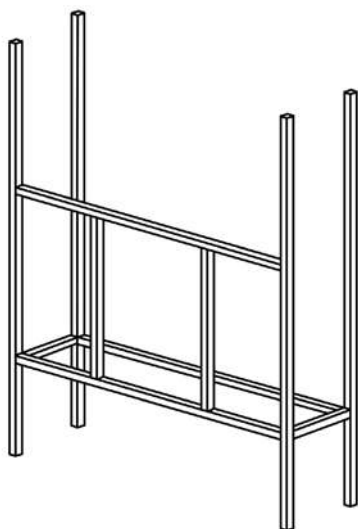

②

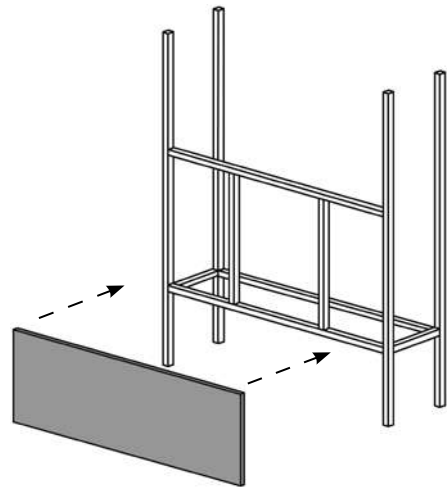

③

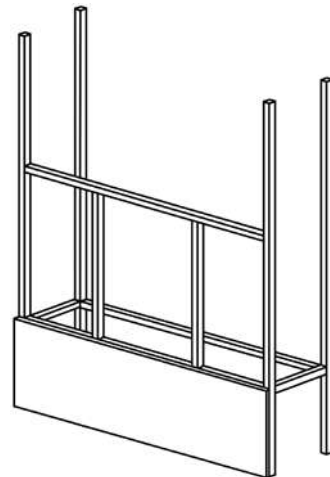

④

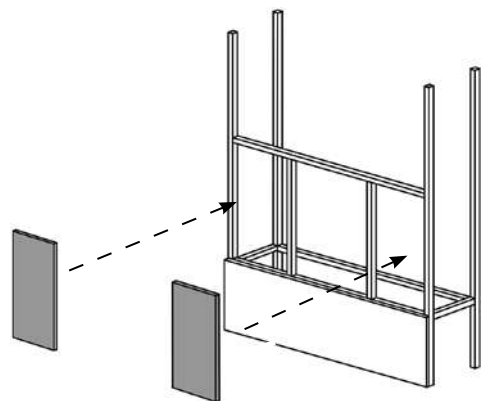

DECORATIVE FRAME STUDWORK INSTALLATION

5

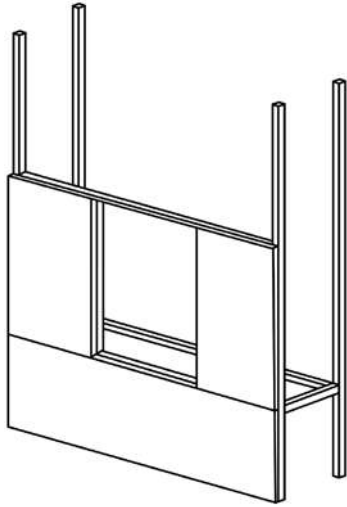

8

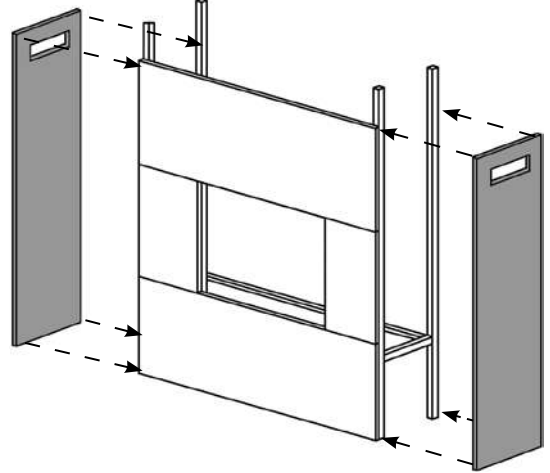

6

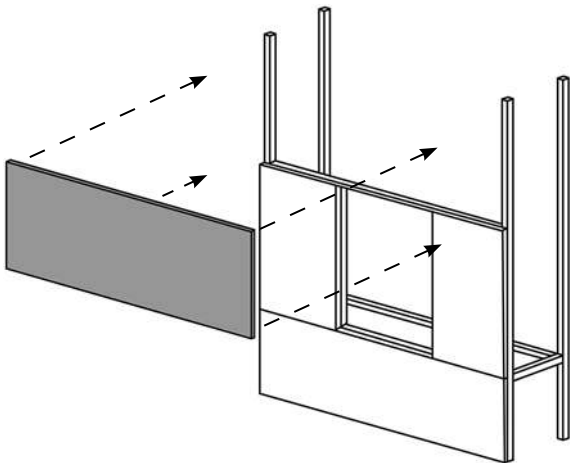

9

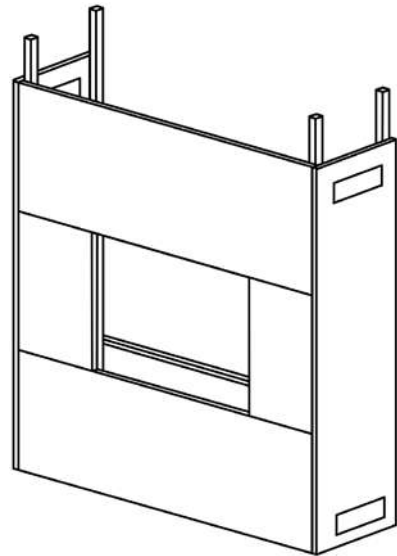

7

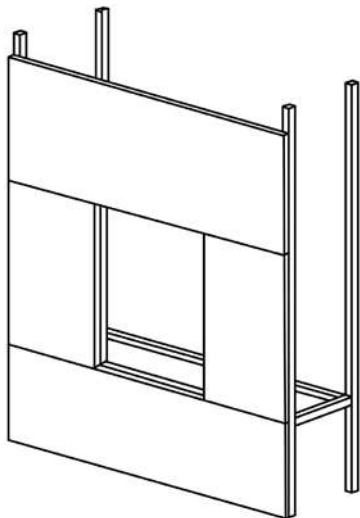

10

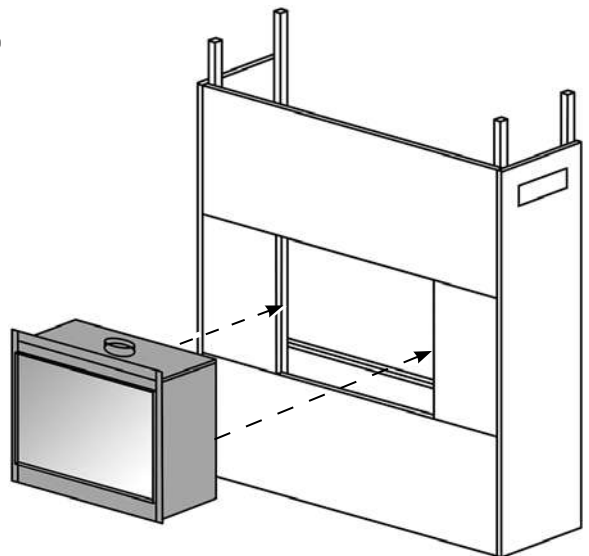

11

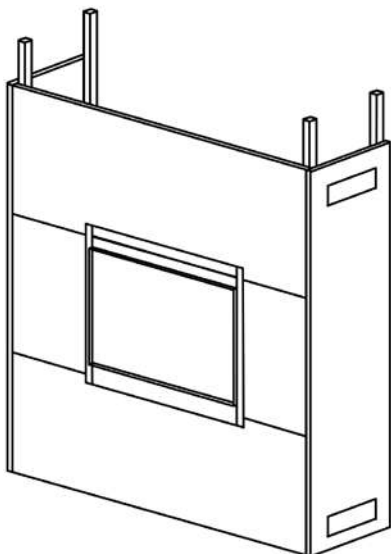

## FITTING THE MAIN CONTROL ASSEMBLY



**Please note:** If you intend to install a MyFire Wi-Fi App with the Reflex 75T it is easier to attach the wire for the receiver box at this stage.

The module and wires for the App can be fitted after installation but access is easier with the Control Box exposed.

Ensure the LED cable and Receiver cable are fed under the front of the firebox aperture and are not trapped.

**NOTE:** If fitting a Wi-Fi module, the Wi-Fi cable must also be fed under the firebox aperture.

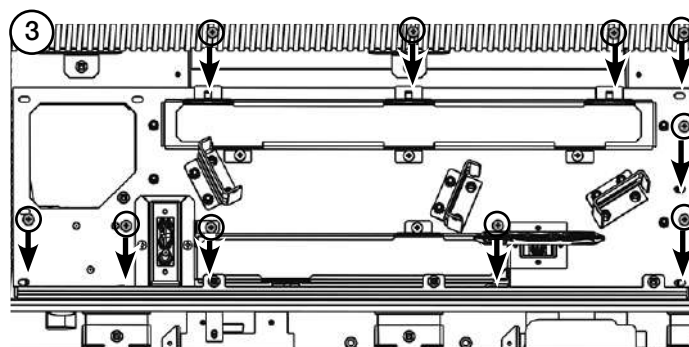
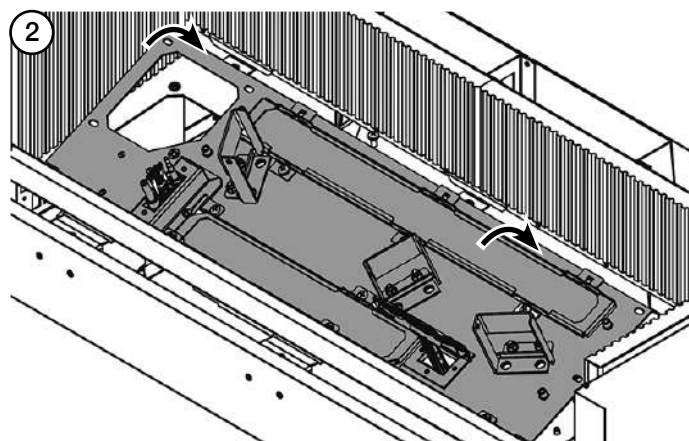
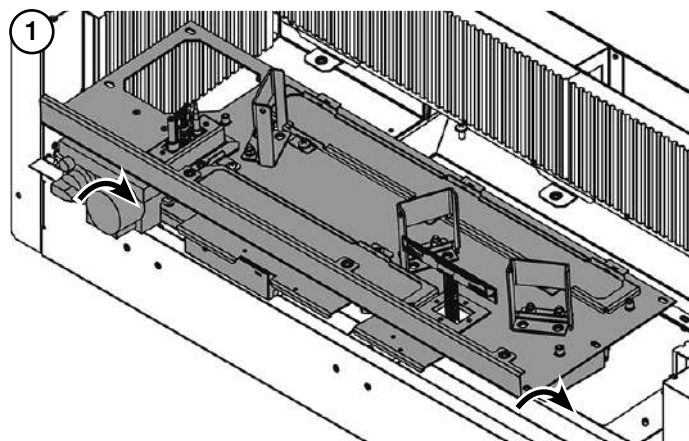

Reconnect the Mains Lead Plug, the LED leads and the receiver lead from the Module and the Wi-Fi box (if installed),

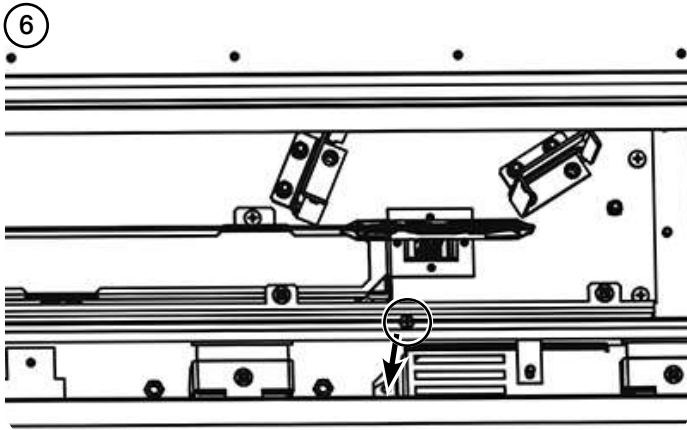
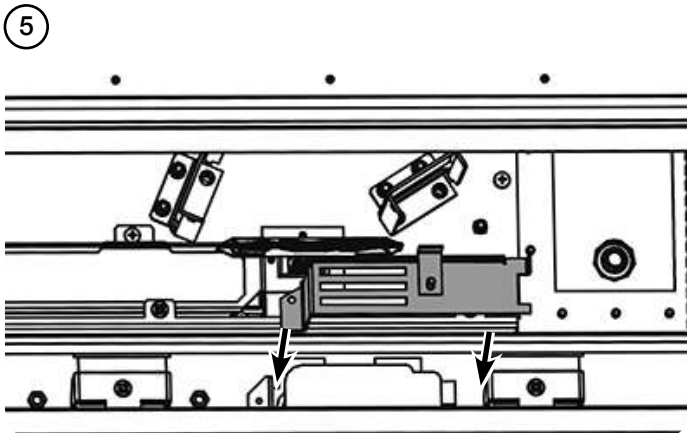
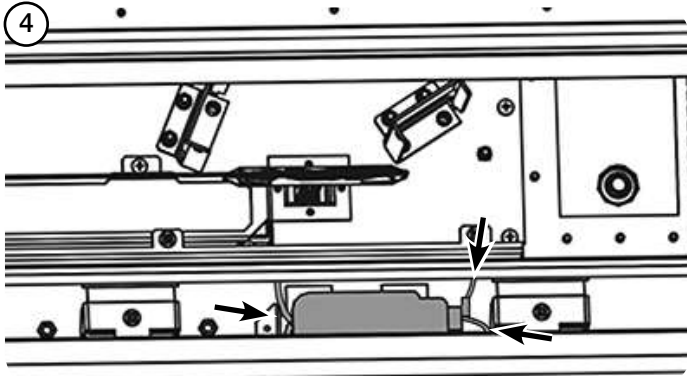

Connect power to the appliance.

## GAS SOUNDNESS PRESSURE CHECK

Connect a pressure gauge to the test point

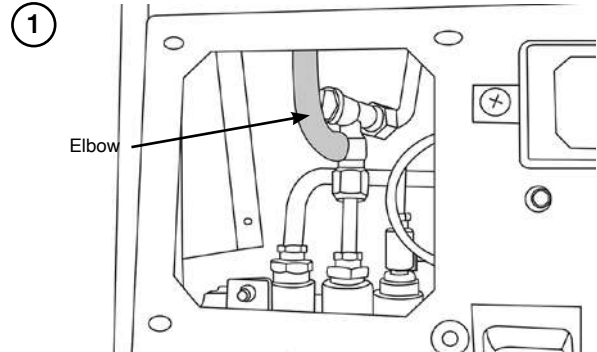

Turn the gas supply on.

Loosely place the appropriate burners onto the injectors.

Light the appliance and check all gas joints for possible leaks. Turn the appliance to maximum and check that the supply pressure is as stated on the databadge.

Turn the appliance off.

Replace the test point screw and check the test point for leaks.

Remove the burners. Take care as the burners will be hot.

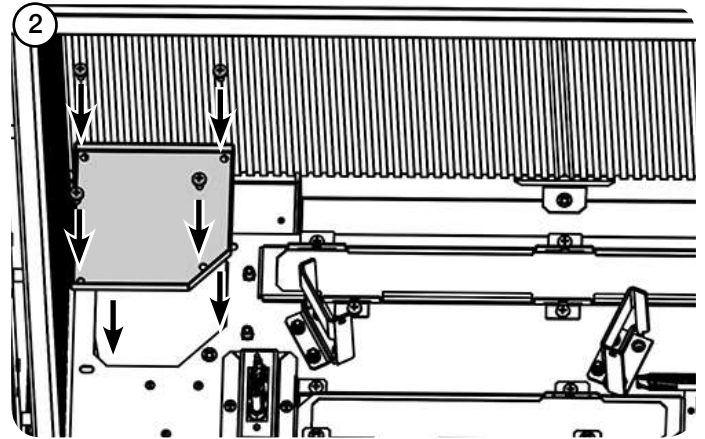

## ASSEMBLING THE FUEL BED

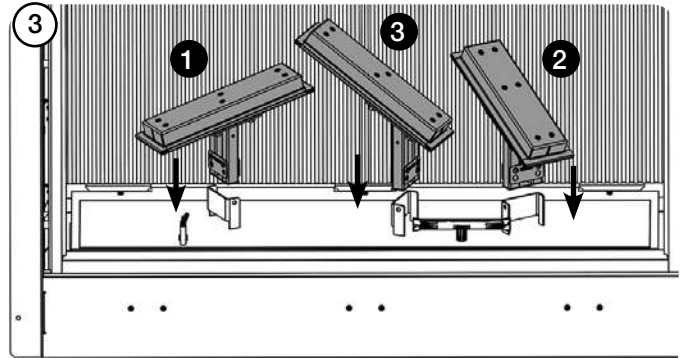
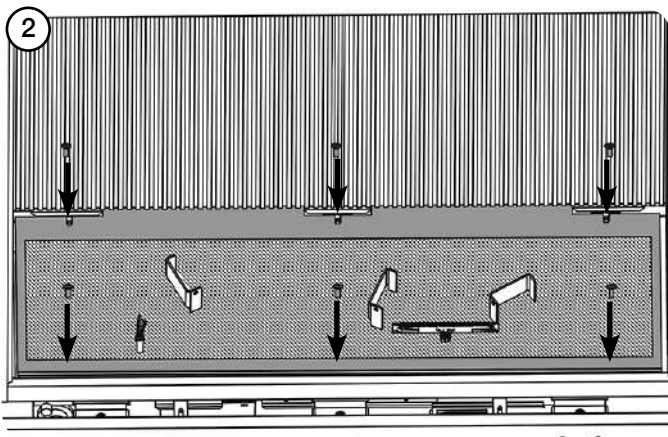
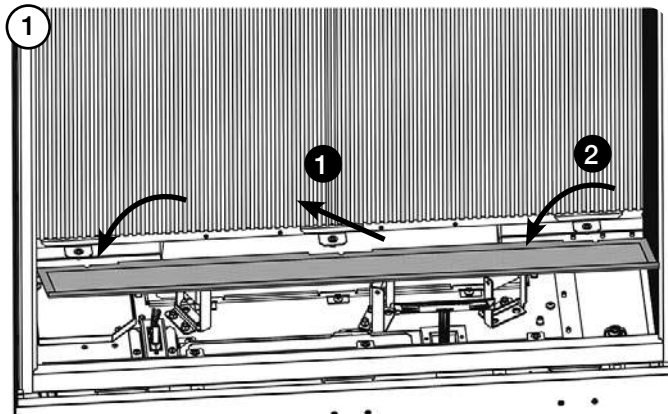

NOTE: RH BURNER IS SHORTER.

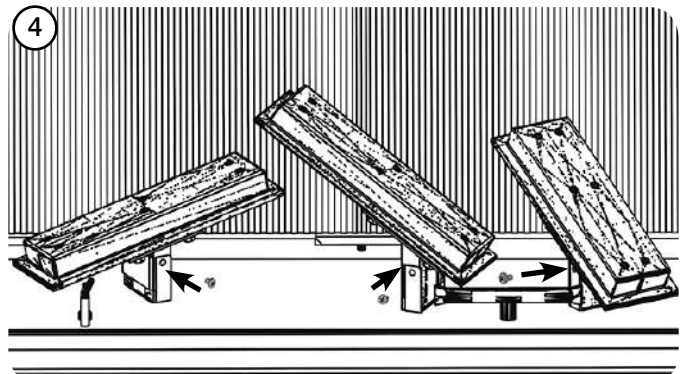

## ARRANGEMENT OF FUEL BED COMPONENTS

**TAKE CARE NOT TO SPILL THE FUEL EFFECT INTO THE PILOT AREA.**

**ONLY GENUINE GAZCO PARTS CAN BE USED IN THIS APPLIANCE.**

Use the entire bag of supplied Amber Effect.

The Shale Effect is supplied as large pieces which will need to be broken into 2-3 smaller shards before placing onto the fuel bed. It is not necessary to use all the supplied Shale Effect.

**LOGS MUST BE POSITIONED ACCORDING TO THE FOLLOWING INSTRUCTIONS TO GIVE THE CORRECT FLAME EFFECT.**

**THE 3 BURNER LOGS MUST LOCATE CORRECTLY ONTO THE LOG BURNERS. ENSURE THE AMBER EFFECT DOES NOT CAUSE THE LOGS TO LIFT OFF THE BURNER.**

Ensure the Burner Tray and Log Burners are clean and free from any debris.



LOG LAYOUT

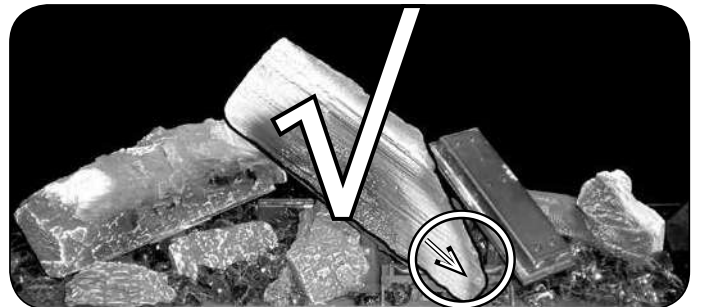
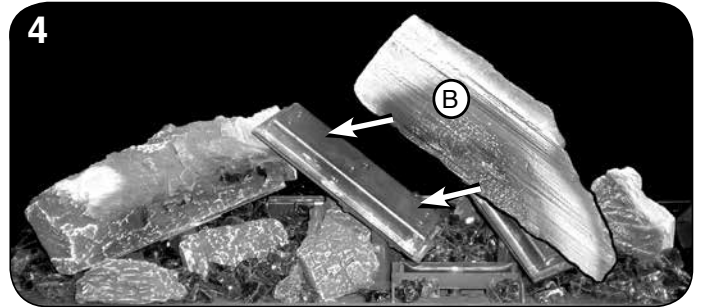
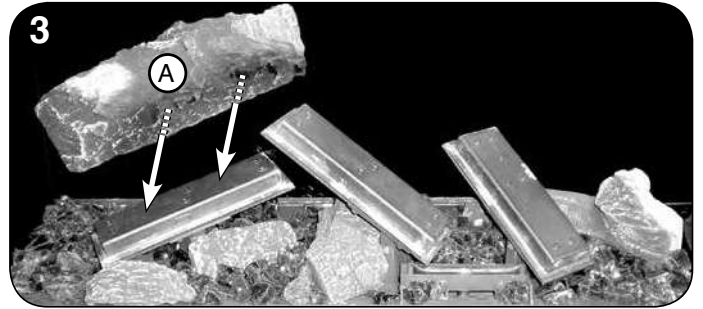
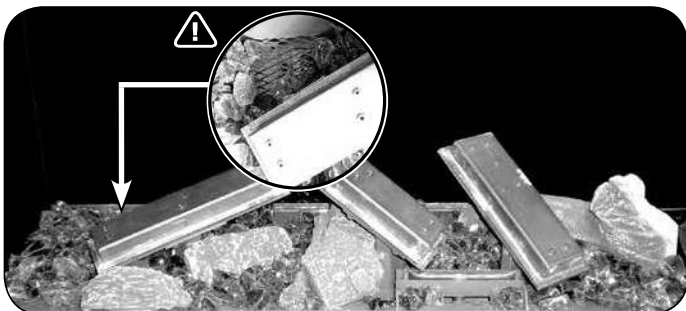
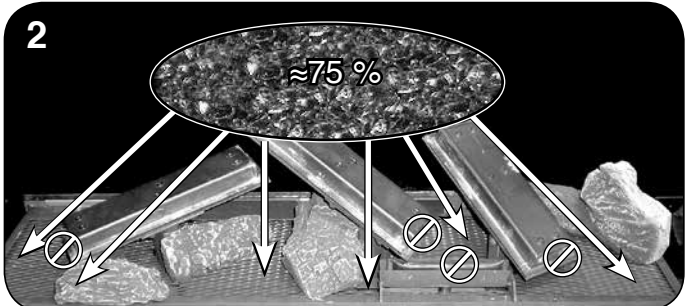
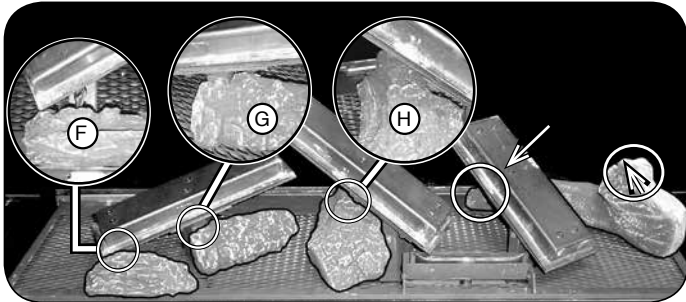
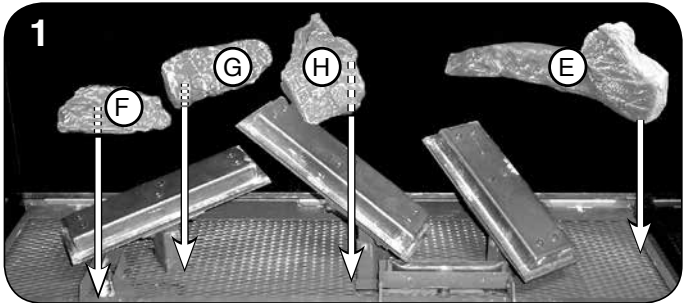
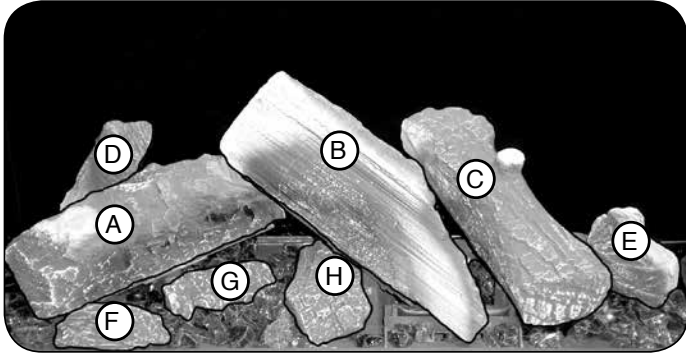



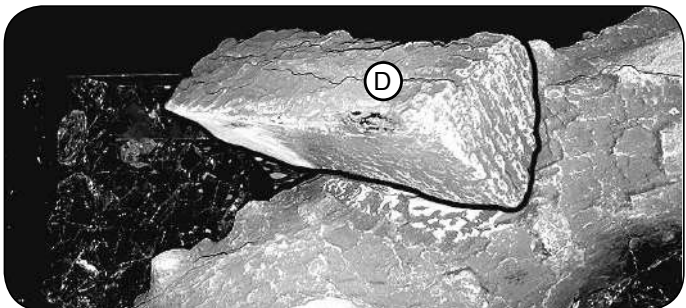
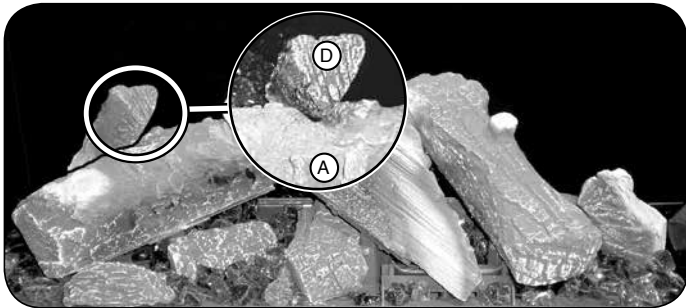
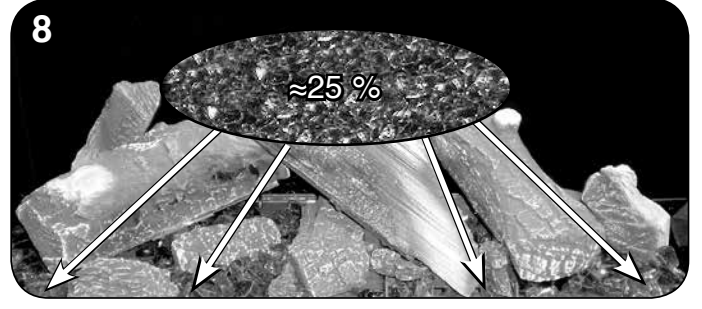
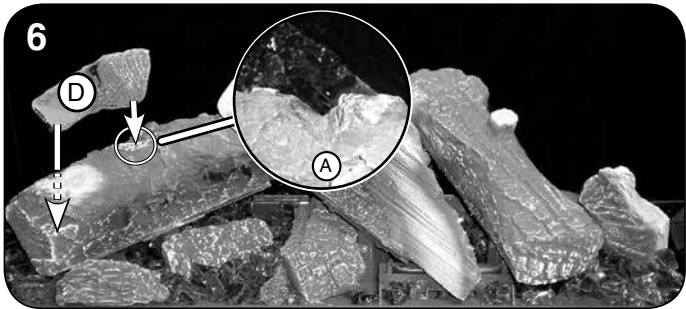
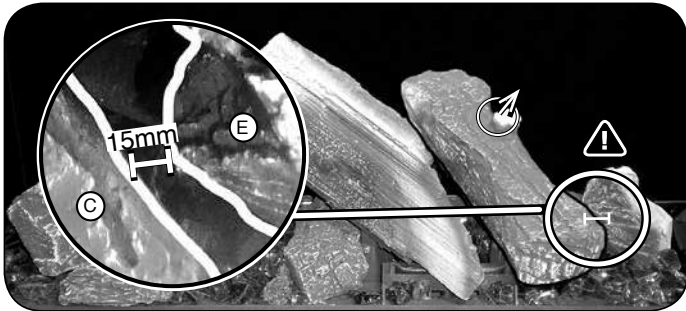
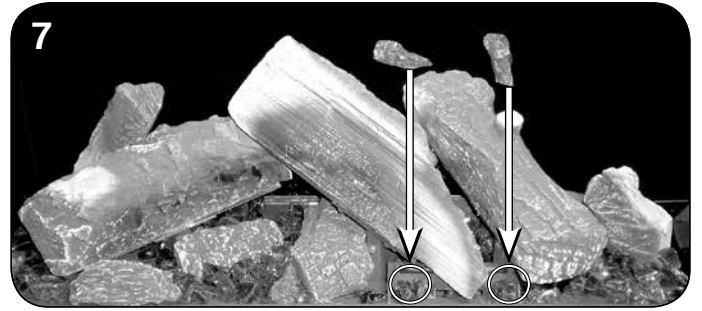

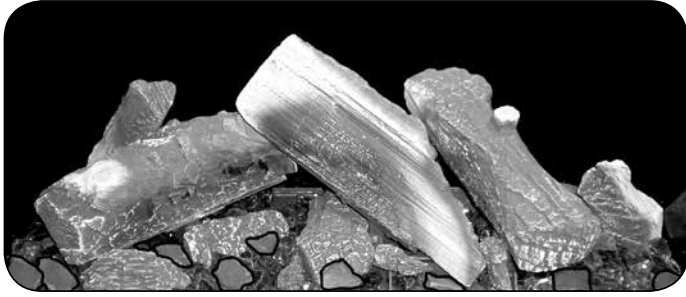

**WARNING - DO NOT PLACE**

**COMPLETION OF ASSEMBLY**

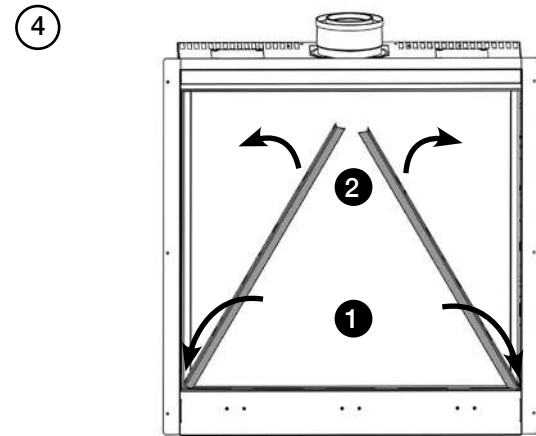
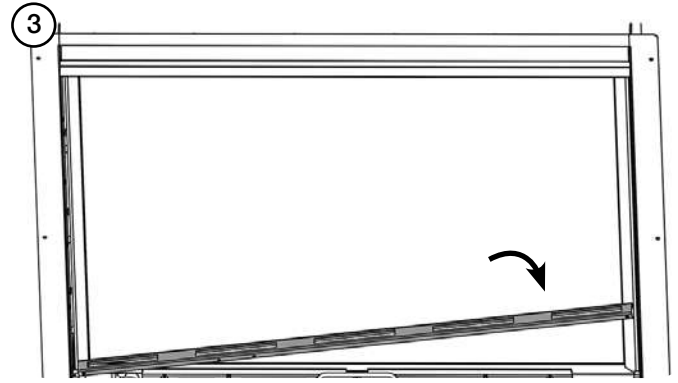
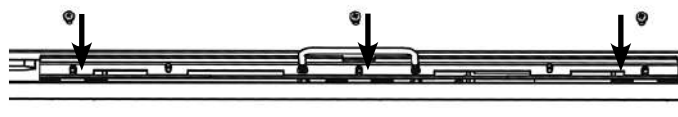
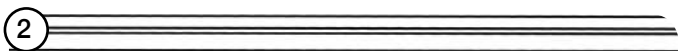
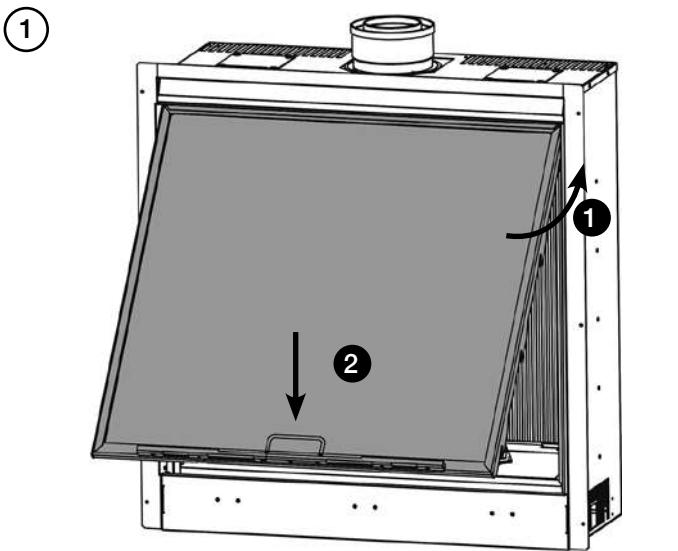

**REPLACE ALL OF THE SECURING SCREWS, ENSURING THAT A SCREW IS PRESENT IN ALL FIXING SLOTS.**

**UNDER NO CIRCUMSTANCES SHOULD THE APPLIANCE BE USED IF ANY OF THE GLASS FRAME RETAINING SCREWS RE LOOSE OR MISSING.**

**NEVER OPERATE THE APPLIANCE WHEN THE GLASS PANEL IS REMOVED OR BROKEN.**

Replace the decorative front by referring to the separate leaflet supplied with the front.



## LIGHTING THE APPLIANCE

The appliance is operated by thermostatic and programmable remote control.



Via the remote it is possible to control the following features:

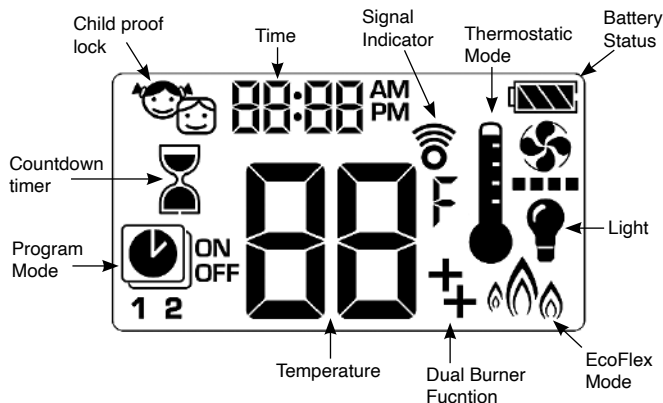

## TURNING THE APPLIANCE OFF (STANDBY)

Press and hold the  button to turn the appliance off.

NOTE: There is a 5 second delay before the next ignition is possible.

## TROUBLESHOOTING



**IMPORTANT:** In the unlikely event that the handset fails to communicate correctly with the appliance it may be necessary to turn off the gas supply at the isolation valve until any problems can be resolved.

The gas meter and isolation valve can be located outside in a meter box, under the stairs, beneath the kitchen sink or in the garage. Whilst this list is not exhaustive, it is important to be able to identify the location of the valve in case of any gas emergency.

To turn off the gas supply, simply turn the handle so the lever is at 90 degrees to the upright gas pipe.

If you smell gas, open doors and windows and never operate any electrical switches. Immediately call the Gas Emergency Services on 0800 111 999.

## TURNING THE APPLIANCE ON

The handset controls the appliance from pilot ignition through to shut down.

To turn the fire on press the  button until two short signals and a series of blinking lines on the handset confirm the start of the ignition sequence and there will be a clicking sound as the valve opens on the appliance.

**The pilot will ignite and the remote is now in Manual Mode. The first time the appliance is turned on it will light in the High position.**



**IMPORTANT: YELLOW FLAMES TYPICALLY APPEAR WHEN THE APPLIANCE HAS REACHED NORMAL OPERATING TEMPERATURE. THIS CAN TAKE UP TO 30 MINUTES.**



**WARNING: IF THE APPLIANCE FAILS TO LIGHT OR BECOMES EXTINGUISHED IN USE, WAIT 3 MINUTES BEFORE ATTEMPTING TO RELIGHT.**

## MYFIRE WI-FI INSTALLATION

**BEFORE UNDERTAKING ANY WORK SWITCH OFF THE APPLIANCE AND ISOLATE THE POWER SUPPLY ENSURING THERE IS NO POWER TO THE APPLIANCE.**

Remove the Front Glass.

Remove the 3 screws securing the Cam Lock Brackets and the Glass Support bracket.

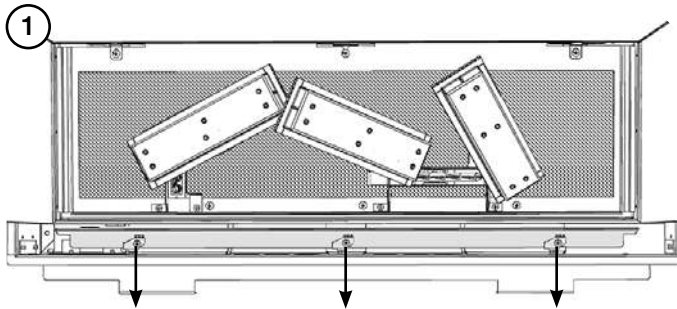

Lift the brackets away from the appliance.

Connect the module lead to the Wi-Fi module.

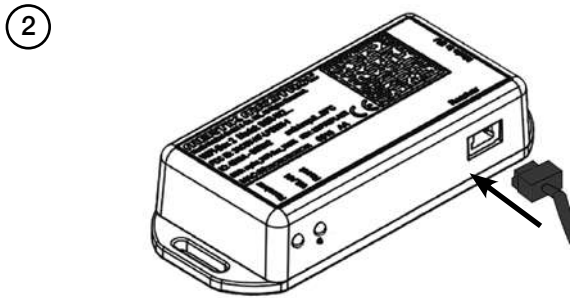

Position the Wi-Fi module in the Wi-Fi module bracket.

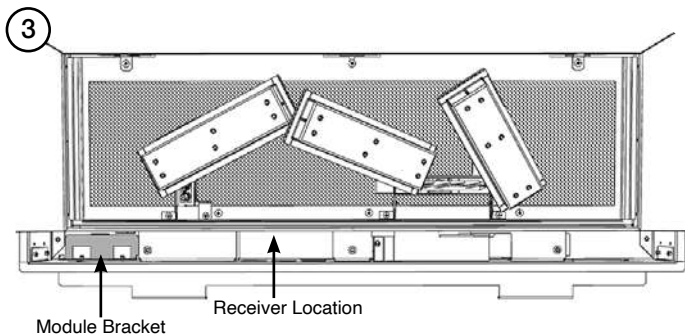

The receiver is located beneath the Main Control Assembly, close to the pilot area.

Using long nose pliers connect the other end of the module lead to the receiver.

**Note: Do not force the connector into position, ensure the connector is at the correct orientation before inserting.**

Ensure the module lead runs **underneath** the front panel spacer.

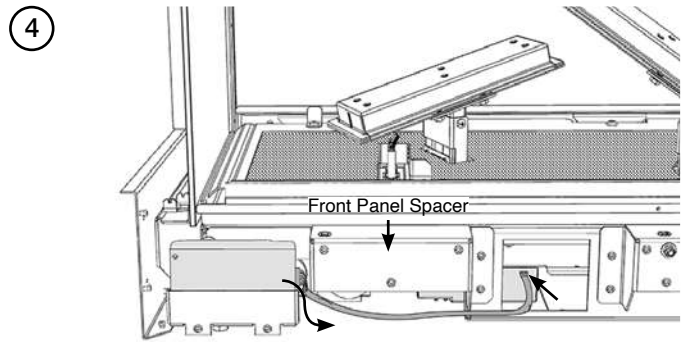

Front Panel removed for clarity

This should complete the wiring circuit as shown.

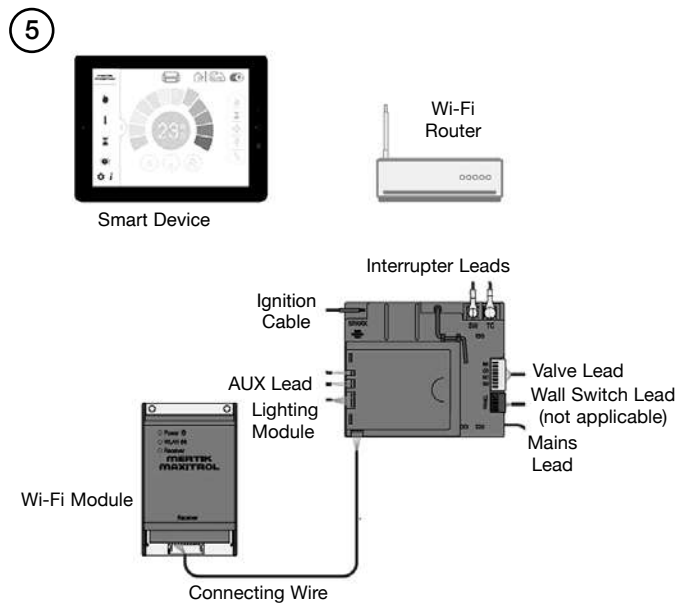

**NOTE: Ensure none of the wires are snagged or caught on any internal components.**

**Follow the steps listed in the MyFire App Setup manual PR2467 to connect a smart device to the fire.**

Replace the Front Glass, Cam Lock Brackets, Glass Support Bracket, and trims.

**ENSURE THAT THE GLASS BRACKETS ARE SECURE AND IN THE ORIGINAL ORIENTATION.**

The installation is now complete.



**Once the Wi-Fi module has been installed and connected to a power source there is a 24 hour window to complete the setup process on the MyFire app.**

**If setup is not completed in this window the Wi-Fi module will have to be manually reset to complete setup, see Page 34 & PR2467 MyFire App Setup.**

Once fitted, remove the trims to access the Wi-Fi module.

## MYFIRE WI-FI SET UP & TROUBLESHOOTING

The MyFire Wi-Fi box must be wired according to the MyFire set up diagram and connected to the receiver, which is in turn connected to the mains power.

Ensure the device is running the most up to date operating system as older models may not be compatible with the MyFire App.

After 30 seconds the MyFire Box goes into Access Point Mode (Green LED flashes). See MyFire App instructions supplied and configure the router.

The following things can affect the Wi-Fi signal on the appliance:

1. Multiple users on the same Wi-Fi channel may interfere with the data transfer. Press the reset button on the MyFire Wi-Fi box for 1 second to change the current channel.
2. If the MyFire Wi-Fi box is not connected to the receiver or is not used it will leave Access Point Mode after 24 hours.
3. If there are multiple fireplaces in the household using MyFire Wi-Fi boxes there must be a minimum of 600mm between them to avoid interference.
4. If there are any changes to the home network then the MyFire Wi-Fi set up must be repeated.

Quick Reference Table.

LED INDICATOR FOR MYFIRE WI-FI BOX			
LABEL	LED		STATUS
Power	Blue	On	Power On
		Off	Power Off
WLAN	Green	On	Connected to home network (Wi-Fi Router)
		Off	Not connected to home network (Wi-Fi Router)
		Flashing	MyFire Wi-Fi Box in Access Point Mode
Receiver	Blue	On	Receiver connected
		Off	No receiver connected or connection lost
All LEDs		Flashing	Internal Configuration

It may be necessary to reset the MyFire Wi-Fi box using a paperclip or similar. The table below shows the length of time required for each reset and the confirmation signals.

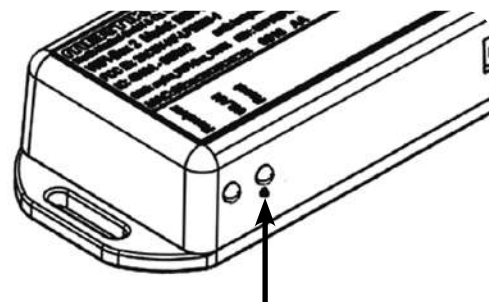

Press Reset Button	LED Status Blue Power LED	Function
1 Sec	Continuously flashes every ½ second	Activates Access Point Mode for 10mins (connect MyFire Wi-Fi module to home network). Simultaneously the Wi-Fi channel changes.
5 Secs	Two rapid flashes every 1 second	System Reset.
10 Secs	Flashes every 100 milliseconds (Continuous)	Restore factory firmware (MyFire Wi-Fi module will set to default after reboot); takes up to 2 minutes.
20 Secs	Flashes every 50 milliseconds (Continuous)	Restores factory firmware and erases all data not locked. (MyFire Wi-Fi module will set to default after reboot); takes up to 2 minutes.

## COMMISSIONING

Complete the Commissioning Checklist at the front of this manual covering:

- Thermocouple soundness checks.  
This is to include ensuring the thermocouple is secure on the pilot bracket assembly, lead connection and integrity.
- Flue checks
- Gas checks
- Log layout - flame picture

For working pressure test, refer to Technical Specifications.

Ensure all safety checks listed in the Commissioning Section are completed, paying particular attention to the glass panel checks and securing of the glass frame.

Upon completion of the commissioning and testing of the installation and correct operation of the appliance, the installer must instruct the user how to operate the appliance.

Guide the user through the User Instructions paying particular attention to:

- a) Regular servicing.
- b) Ventilation - point out the ventilation positions where applicable.
- c) Hot surfaces.
- d) How the appliance works with the remote control handset and the modes of operation.
- e) How to change settings in the auto mode and program modes of operation.
- f) What to do if the appliance fails to operate.

## REPROGRAMMING HANDSET/ CONTROL BOX

To access the control box:

Remove the decorative trim, see Servicing Instructions.

Remove the lower glass retaining bracket, see Servicing Instructions, Page 40.

Access is now possible through the aperture below the centre-left hand side of the appliance using an angled pointed tool.

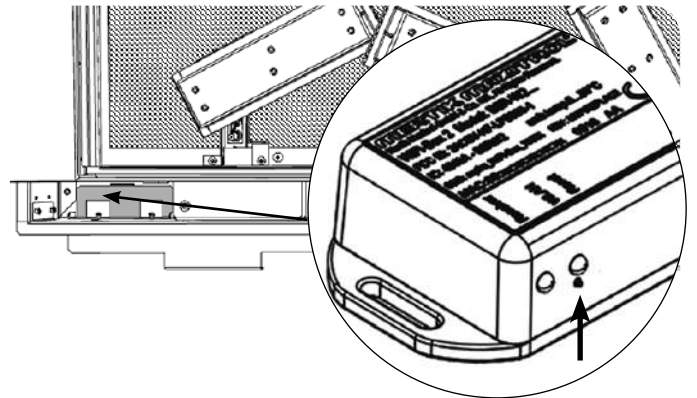

NOTE: Alternatively, the main control assembly can be removed to access the control box, see Servicing Instructions

Press and hold the reset button on the control box until you hear two signals. After the second longer signal:

Release the reset button and within 20 seconds:

Press the DOWN button on the handset until you hear two additional short signals confirming the new code is set. If there is a single long signal the code learning sequence has failed or the wiring is incorrect.

**Note: When pressing the DOWN button on the handset if two beeps are not heard:**

Release the DOWN button and CONN will be displayed on the handset screen. An 8 second count will start on the handset screen followed by two short beeps confirming the new code is set. If there is a single long signal the code learning sequence has failed or the wiring is incorrect.

Replace the lower glass bracket by setting the cam locks in position with the door tool and tightening the screws.

**Ensure the Front Glass is aligned with the Side Glass.**

## SERVICING REQUIREMENTS

**IMPORTANT – The glass panels on this appliance should be checked for any signs of damage on the front face of the glass panel (scratches, scores, cracks or other surface defects). If damage is observed, the glass panel must be replaced and the appliance must not be used until a replacement is installed. Under no circumstances should the appliance be used if any damage is observed. Please isolate the appliance until a replacement glass panel has been obtained and installed. Replacement glass panels can be purchased from Gazco via the retailer from which the appliance was purchased or any other Gazco distributor.**

This appliance must be serviced at least once a year by a competent person.

All tests must be carried out in accordance with the current Gas Safe recommendations.

### Before Testing:

- Conduct a gas soundness test for the property ensuring there are no leaks before servicing.
- Check the operation of the appliance before testing.

### Special checks:

- Clean the burners using a vacuum cleaner with a soft brush attachment. Ensure all debris is removed from the burner ports.
- Clean away lint or fluff from the pilot.
- Clean away lint or fluff from under the burner.
- Check the spark gap on the pilot is correct.
- Check that the Pilot ignites correctly and Main Burner cross lights smoothly.
- Ensure that the glass is secured correctly and that all retaining screws are in place.

Correct any faults found during the initial test.

Re-commission the appliance in accordance with Commissioning Procedures of these instructions.

Advise the customer of any remedial work undertaken.

### ELECTRONIC CONTROL VALVE FAULT ANALYSIS

SYMPTOM	CAUSE	REMEDY
Frequent beeps for 3 seconds after operation request	Loose/damaged wire	Check interrupter block and wires
No ignition, no tone, motor turns slightly when operated	Receiver board damaged	Replace receiver
No pilot flame and control continues to spark	Thermocouple circuit wired incorrectly	Correct wiring
Pilot lights, control continues to spark, valve shuts down after 10 - 30 seconds	1. No spark at pilot burner 2. Loose/damaged wire	1. Rectify spark at pilot burner 2. Check interrupter and wires
Rear burner can not be turned off - valve can be heard to operate.	Faulty Solenoid Valve	Replace Solenoid Valve
Rear burner can not be turned off - no beep or noise from solenoid	1. Faulty wire/ wire not connected 2. Faulty receiver	1. Replace wire/ solenoid 2. Replace receiver

FAULT FINDING CHARTS

IGNITION FUNCTIONAL CHECK 1

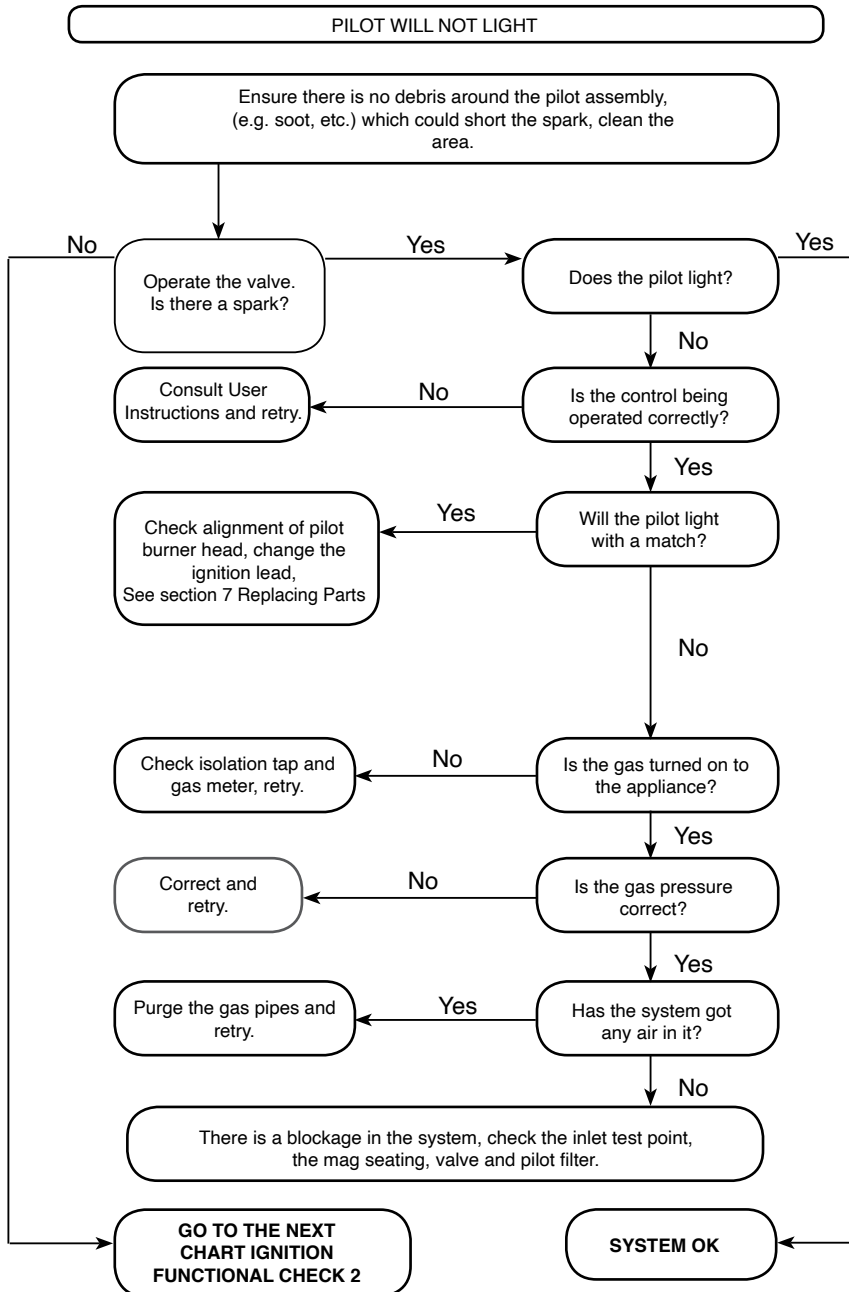





## GENERAL

All main components can be replaced without removing the appliance from its installation.

**DISCONNECT MAINS ELECTRICAL SUPPLY AT THE ACCESSIBLE PLUG OR DEDICATED SWITCH BEFORE SERVICING THE APPLIANCE.**

**IT IS ESSENTIAL THAT THE GAS SUPPLY TO THE APPLIANCE IS TURNED OFF AT THE ISOLATION DEVICE BEFORE PROCEEDING FURTHER.**

It will be necessary to remove the burners and the fuel bed before any of the main components can be serviced.

The Power Module and the Wi-Fi Receiver can be serviced by removing the decorative trim and lower glass retaining bracket.



**DURING SERVICING OF THIS APPLIANCE IT MAY BE NECESSARY TO CUT CABLE TIES IN ORDER TO ACCESS AND REMOVE SOME OF THE PARTS. THESE MUST BE REPLACED WHEN REASSEMBLING THE APPLIANCE.**



**AFTER SERVICING ENSURE THAT ALL CONNECTIONS ARE REPLACED BEFORE REPLACING THE MESH TRAY.**

## REMOVING THE GLASS

1

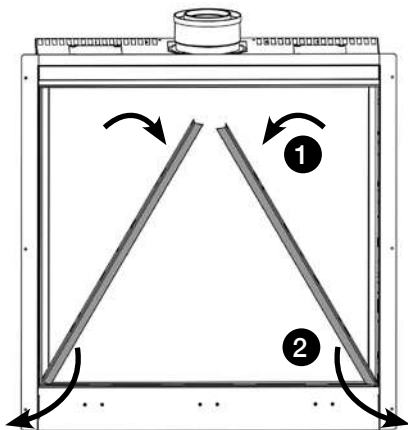

2

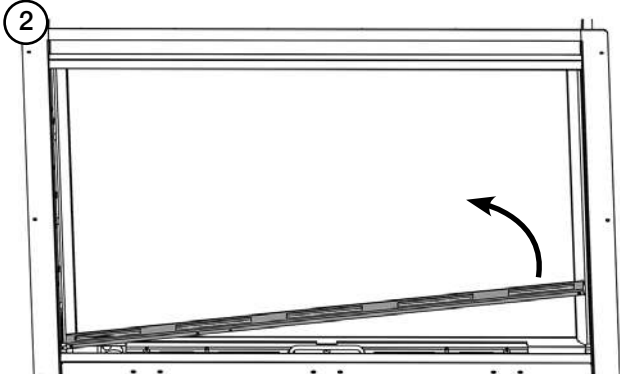

3

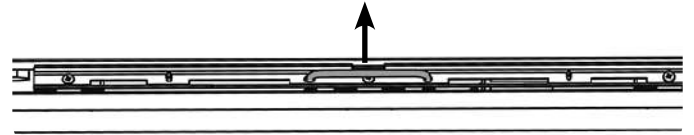

4

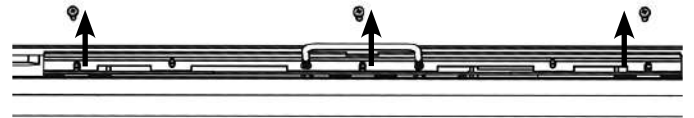

5

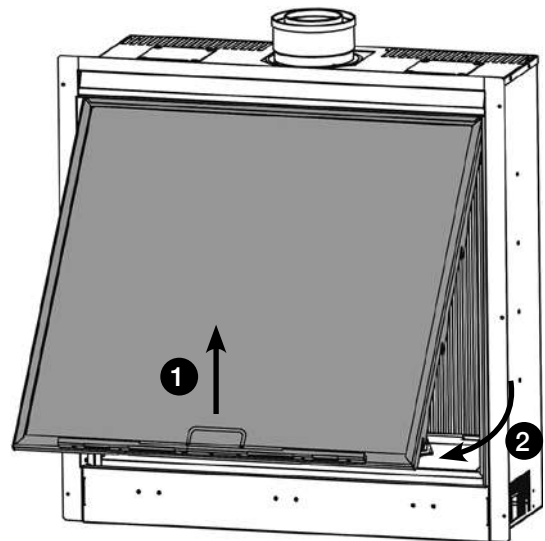

**REPLACE ALL OF THE SECURING SCREWS, ENSURING THAT A SCREW IS PRESENT IN ALL FIXING SLOTS.**

**UNDER NO CIRCUMSTANCES SHOULD THE APPLIANCE BE USED IF ANY OF THE GLASS FRAME RETAINING SCREWS RE LOOSE OR MISSING.**

**NEVER OPERATE THE APPLIANCE WHEN THE GLASS PANEL IS REMOVED OR BROKEN.**



## REMOVING THE FUEL EFFECT

The fuel effect consists of 6 different components.

To avoid damage Logs A, B, C and D should be removed in the following order and placed on a dry, clean surface.

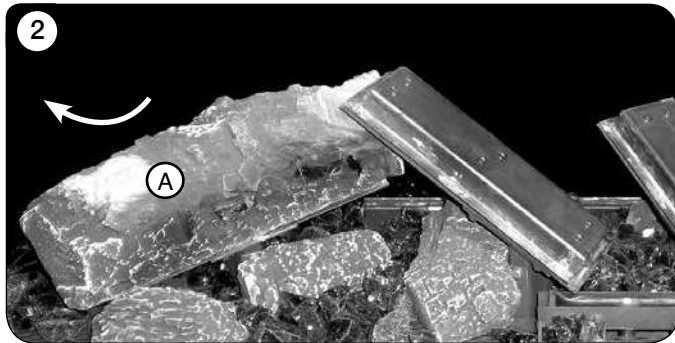
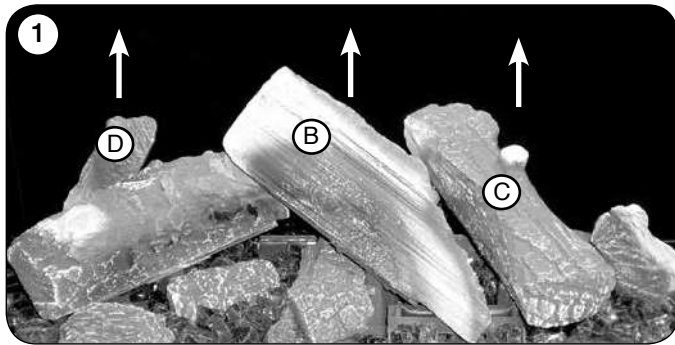

Remove the remaining components:

- Log E.
- Embers F, G and H.
- 2 small Embers.
- Shale Effect.
- Amber Effect.

Keep each component separate for ease of replacing.

## REMOVING THE LOG BURNERS AND MAIN CONTROL ASSEMBLY

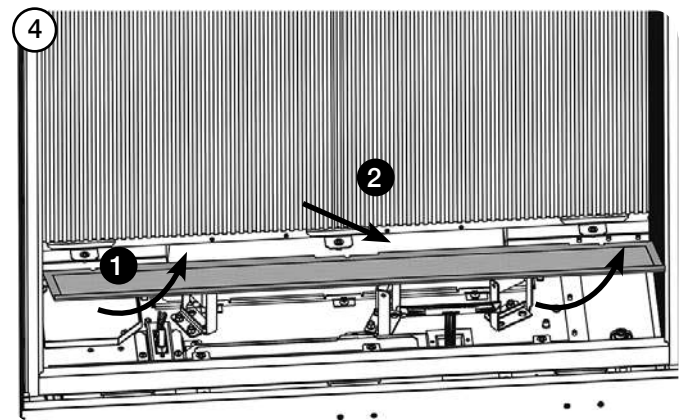
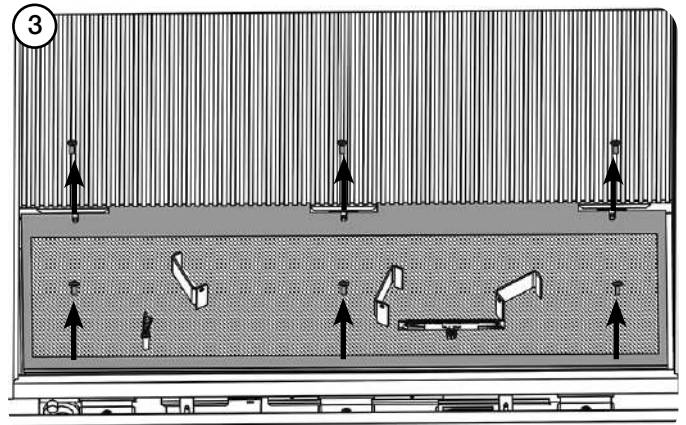
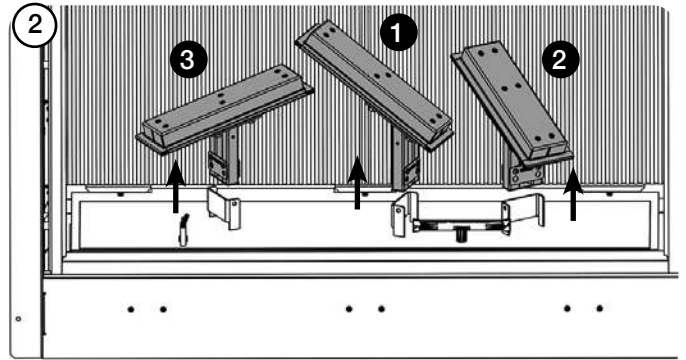
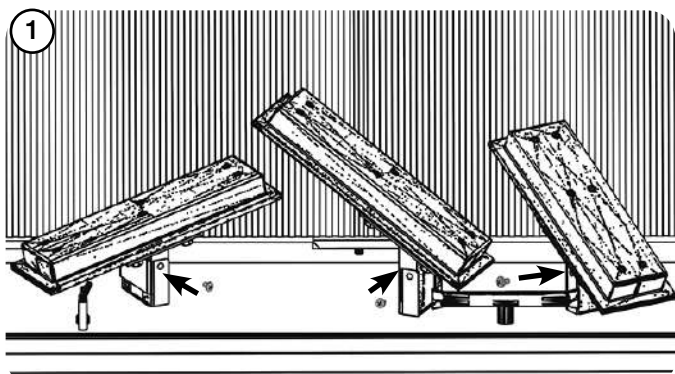

WHEN REPLACING THE MESH TRAY TAKE CARE NOT TO DAMAGE THE LOG BURNER BRACKETS, PILOT AND CROSS LIGHTER. REPLACE THE FRONT SCREWS FIRST BEFORE TIGHTENING THE REAR SCREWS.

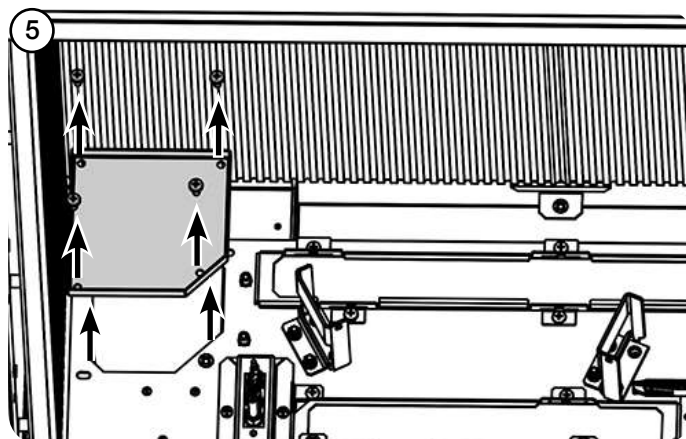

Turn the gas supply off at the isolation device.

**HAVE YOU ISOLATED THE GAS SUPPLY?**

Disconnect the isolating device from the appliance inlet pipe to isolate the gas supply.

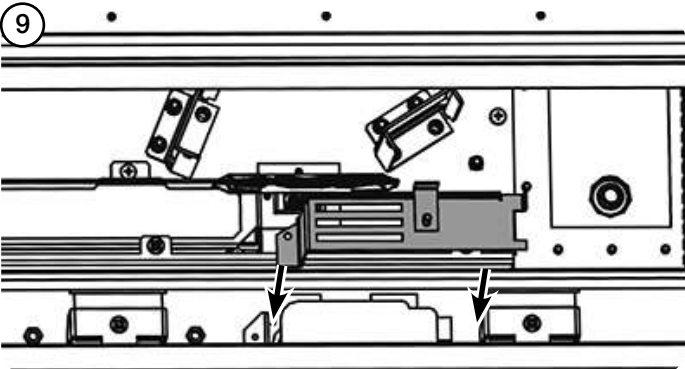
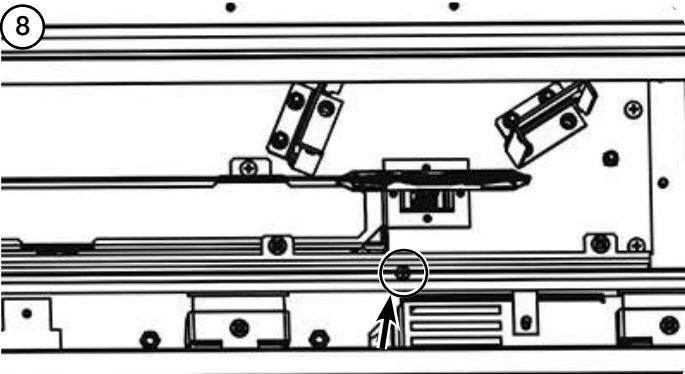
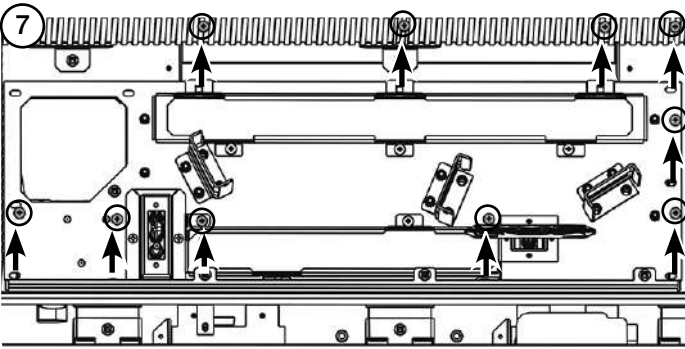
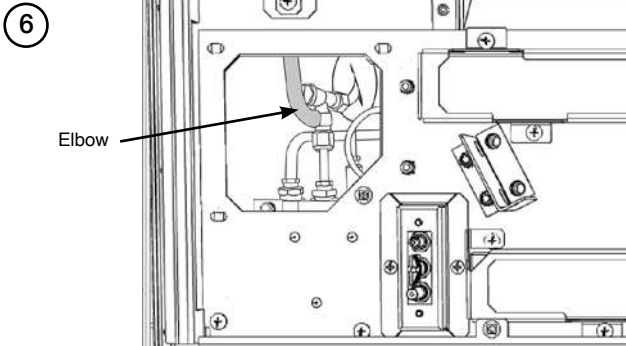

Disconnect the LED lead and the Receiver lead from the power module, if fitted, disconnect the Wi-Fi lead from the Wi-Fi module (if installed).

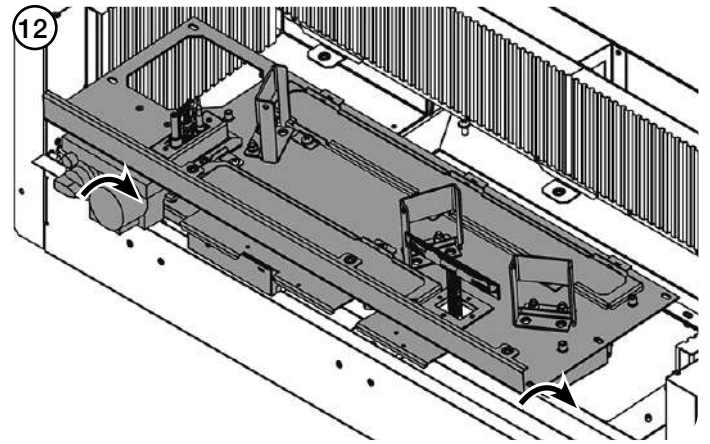
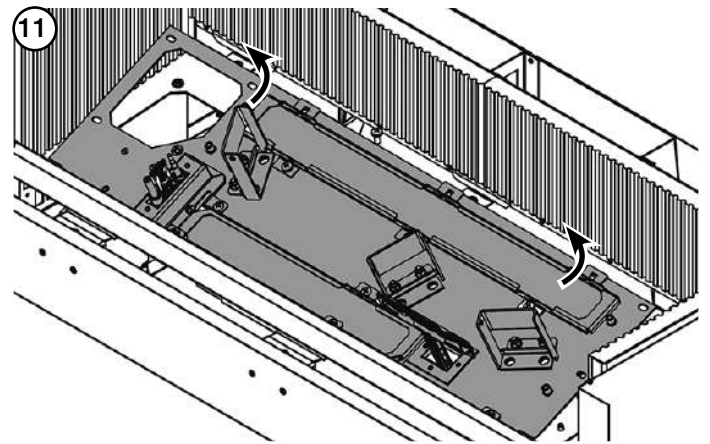
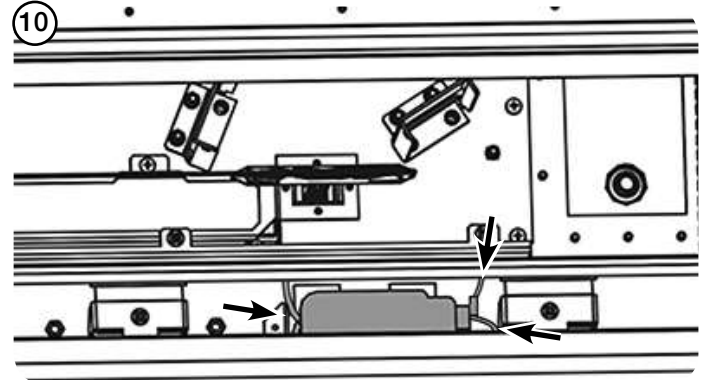

**! AFTER SERVICING ENSURE THAT ALL CONNECTIONS ARE REPLACED BEFORE REPLACING THE MESH TRAY.**



## REPLACING THE LED CIRCUIT

There are 3 LED boards, which can be replaced individually.

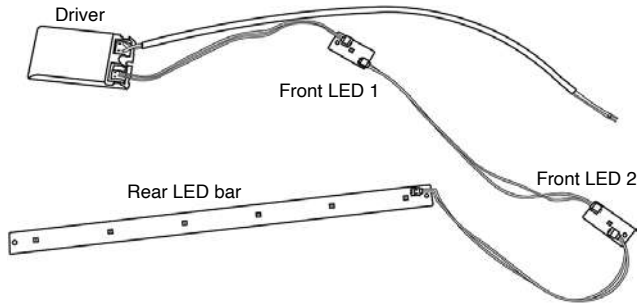

**THE LED'S ARE FRAGILE. HANDLE WITH CARE. ONLY HOLD THE LED BOARDS BY THE EDGES TO AVOID CONTACT WITH THE TOP OF THE LED'S.**

**AVOID CATCHING ANY DELICATE WIRES WHEN REPLACING THE SCREWS.**

### FRONT LED BOARDS

There are two LED boards located on a shelf below the top of the Control Assembly.

Remove the Main Control Assembly for access.

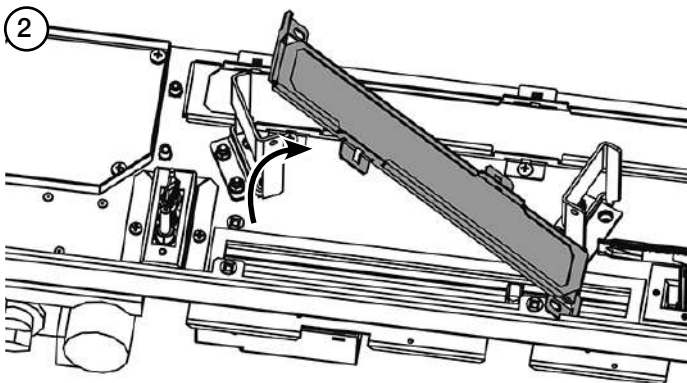
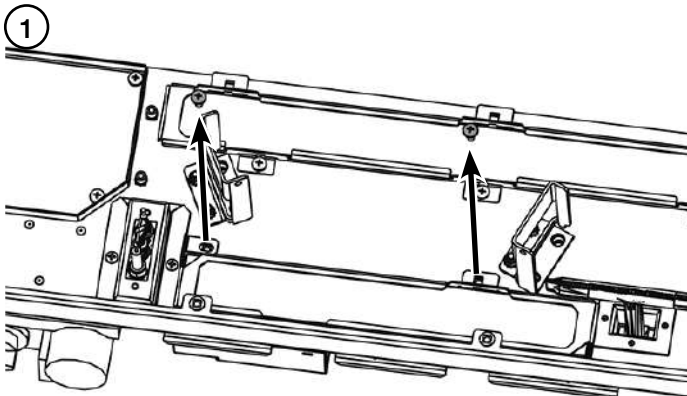

Remove the 2 screws holding the LED boards to the Control Assembly by inserting a screwdriver through the gap previously covered by the glass bracket.

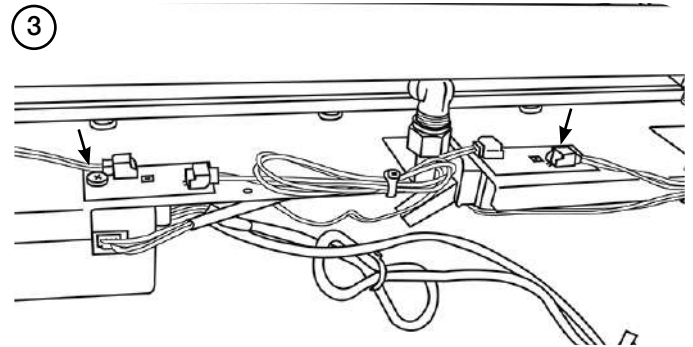

The boards can now be replaced.

NOTE: Each board has the wiring direction marked as IN or OUT on each end to ensure the replacement boards are wired correctly.

### REAR LED BAR

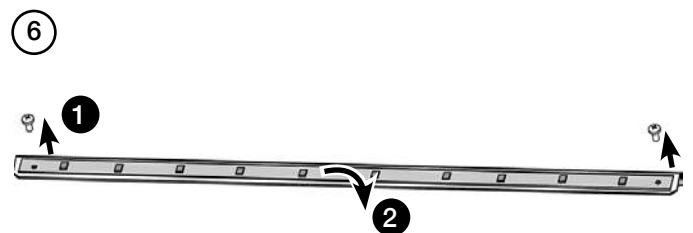
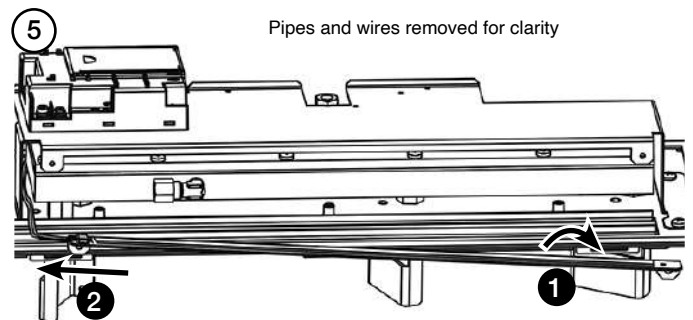
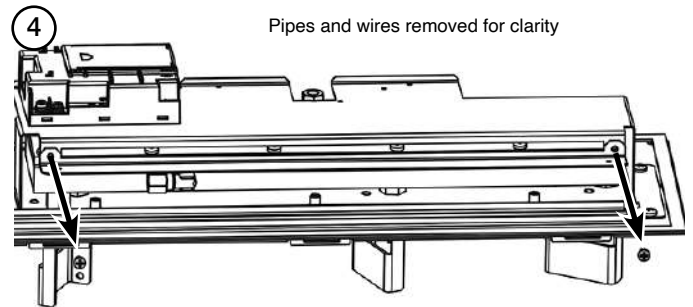

### DRIVER

The driver is located in the underside of the Main Control Assembly next to the latching Solenoid.

This is a non-serviceable part.

## REPLACING THE MODULE

Remove the module bracket and disconnect the LED plug and Mains Lead from the Module.

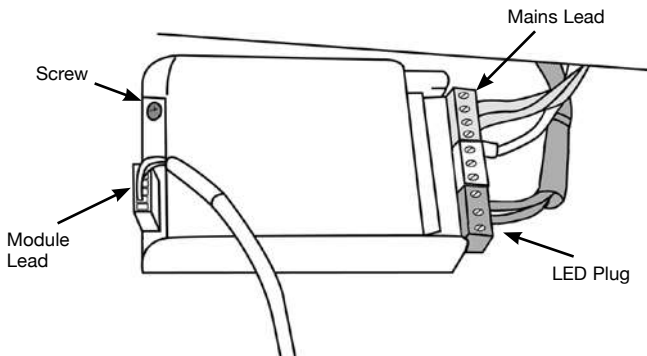

Disconnect the Module Lead.

The Module can now be removed.

Replace in reverse order.

## PILOT UNIT ASSEMBLY

Turn off the gas supply at the isolating device.



**IMPORTANT: UNDER THE TERMS OF THE EXTENDED WARRANTY IT WILL BE COMPULSORY TO CHANGE THE COMPLETE PILOT UNIT ON THIS APPLIANCE IN YEARS 2 AND 4.**

Undo pilot pipe from the control valve (A).

Remove the thermocouple from the interrupter block (B).

Remove the ignition lead from the electrode (C).

Undo the 2 retaining screws from pilot unit bracket.

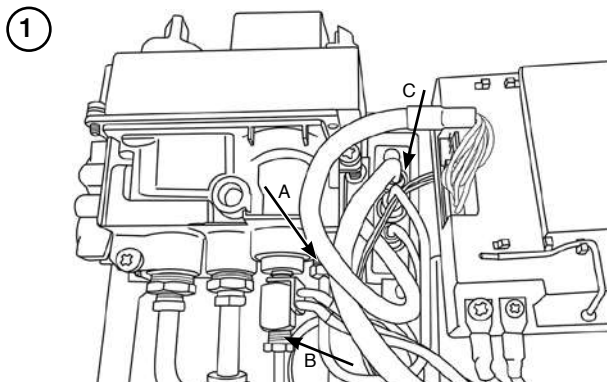

The pilot bracket can now be withdrawn from its cradle.

The pilot assembly consists of three components, which can be individually changed, these are:

Electrode.  
Pilot Injector.  
Thermocouple.

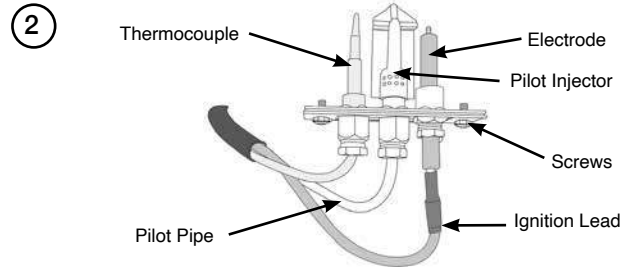

## ELECTRODE

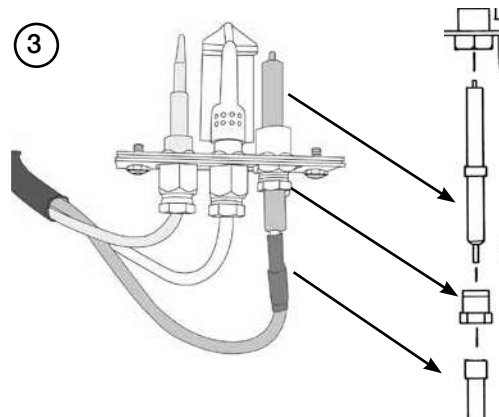

Replace with a new electrode.  
Do not over-tighten the nut; this could break the component.

## PILOT INJECTOR

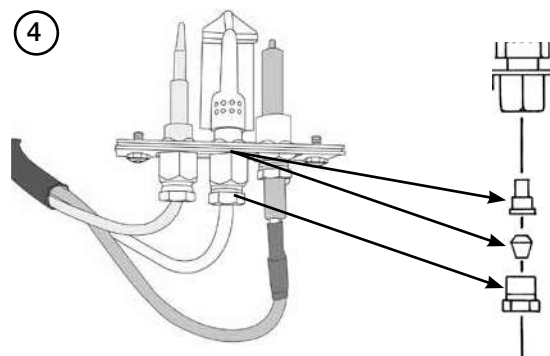

## THERMOCOUPLE

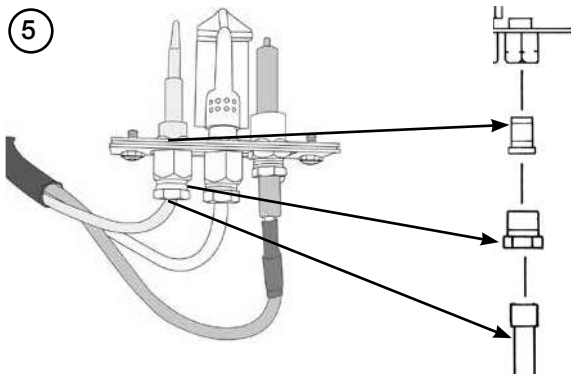

## IGNITION LEAD

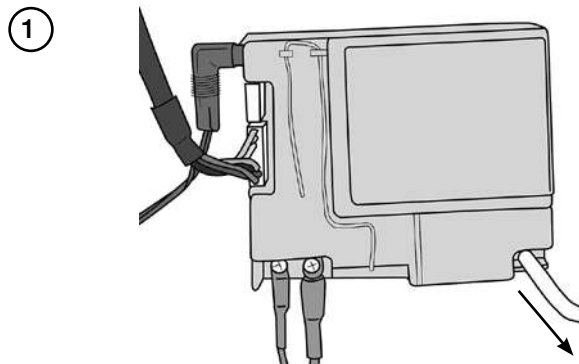

Carefully cut cable ties from the vidaflex and disconnect the lead from the electrode.

**IMPORTANT** Ensure not to cut the cable.

## GAS VALVE

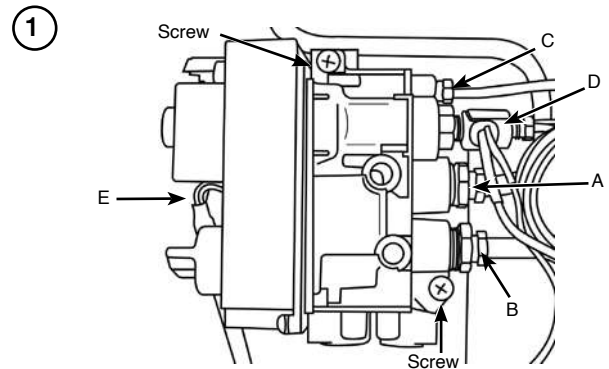

To change the gas valve:

Disconnect the Gas Inlet Pipe, Arrow A.

Disconnect the Gas Outlet Pipe, Arrow B.

Disconnect the Pilot Pipe, Arrow C.

Disconnect the Thermocouple, Thermocurrent Wires and the Interrupter Block, Arrow D.

Remove the Eight Wire Loom, Arrow E.

There is an access hole in the top of the Control Bracket to release the locking tab.

Remove the 2 screws securing the Valve to the support bracket and withdraw the Valve.

Replace in reverse order and check for leaks.

## MAGNETIC SAFETY VALVE

Undo the Thermocouple from the Interrupter Block and remove the 2 Interrupter Leads.

Unscrew the Interrupter Block from the back of the Valve.

Undo the silver Magnetic Valve retaining nut on the back of the Valve.

Gently tap out the Mag Valve.

Replace with a new unit.

Reassemble in reverse order ensuring that the interrupter leads are connected correctly with the blue tag lead furthest away from the gas valve body.

Check for leaks.

## CONTROL BOX

Cut the cable tie holding the Ignition lead and the Thermocouple cables.

Disconnect the Module and Solenoid leads from the Control Box.

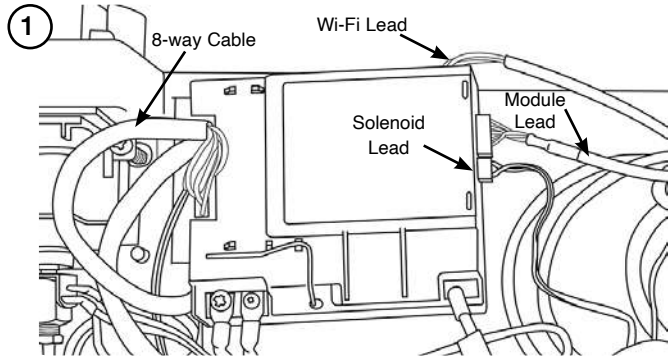

Remove the Ignition Lead.  
The Control Box is held on by Velcro pads.

Remove the 2 screws to remove the 2 Interrupter Leads.

Remove the 8 way cable from the Control Box.

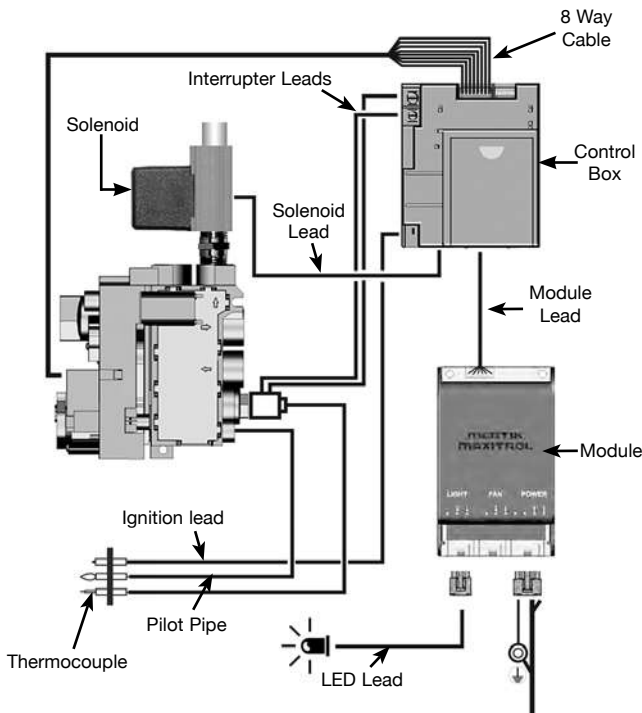

Replace in reverse order.

After replacing the Control Box ensure that all cable ties and connections are refitted, see Diagram 26.

After replacing the Control Box you will need to reprogram the handset.

— Press and hold the reset button on the control box until you hear two signals. After the second longer signal:

— Release the reset button and within 20 seconds:

— Press the DOWN button on the handset until you hear two additional short signals confirming the new code is set. If there is a single long signal the code learning sequence has failed or the wiring is incorrect.

**Note: When pressing the DOWN button on the handset if two beeps are not heard:**

— Release the DOWN button and CONN will be displayed on the handset screen. An 8 second count will start on the handset screen followed by two short beeps confirming the new code is set. If there is a single long signal the code learning sequence has failed or the wiring is incorrect.

## FUEL BED INJECTORS

This appliance has 6 Fuel Bed Injectors.

**NOTE: The injectors are not identical, see Page 12.**

**TO ENSURE CORRECT ASSEMBLY REPLACE EACH INJECTOR INDIVIDUALLY.**

Remove the 2 nuts and lock washers from each Burner Bracket.

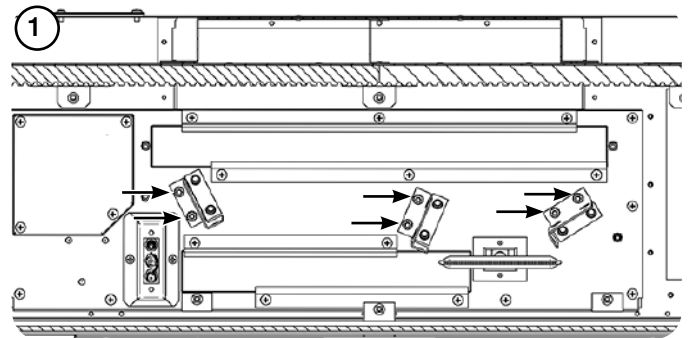

Remove the Gasket.

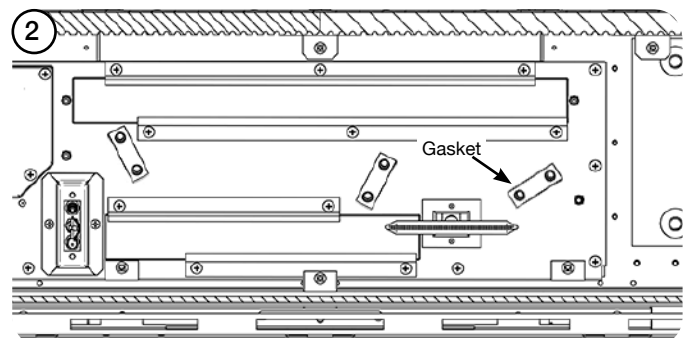

Undo the Injectors individually and remove the fibre washer.

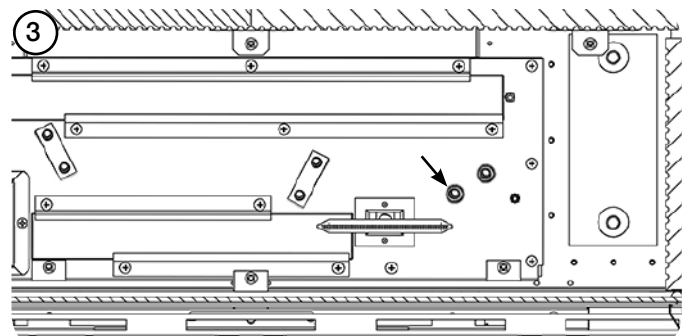



Replace with the correct size Injector.  
**DO NOT OVERTIGHTEN.**

Use thread sealant Loctite 572 when replacing Injectors.

Repeat for the remaining Injectors.

Check for leaks.

## CROSS LIGHTING INJECTOR

Turn the Main Control Assembly over to access the components on the underside.

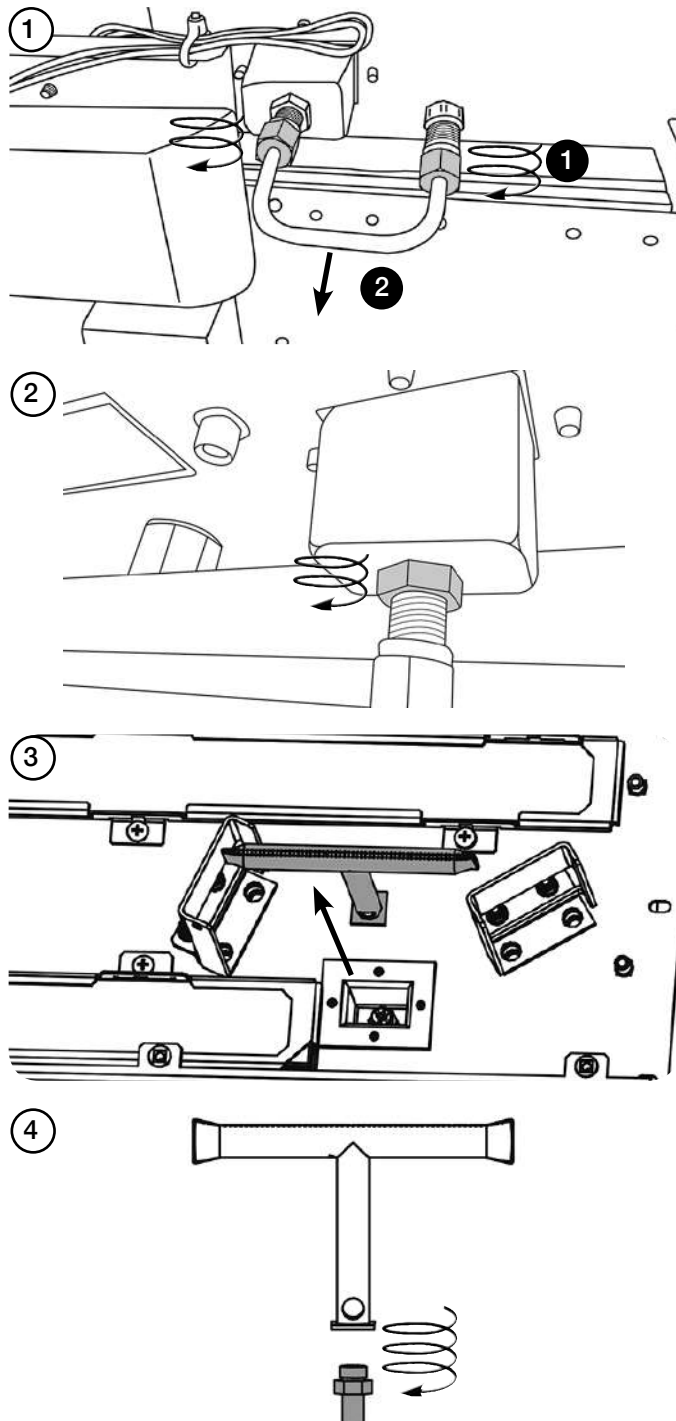

Replace with the correct size Injector and refit all components in the reverse order.

Check for leaks.

## LATCHING SOLENOID

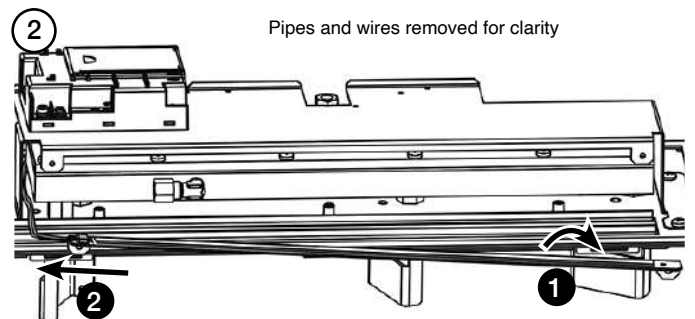
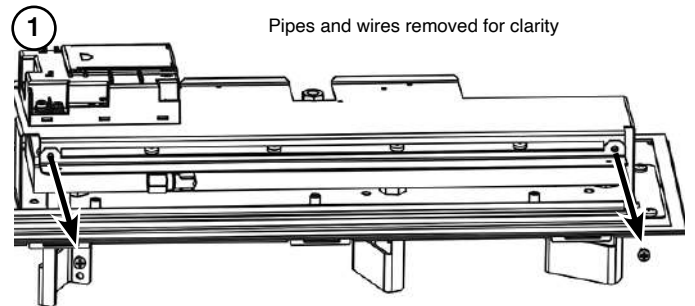

Undo the three nuts shown and free the solenoid from the pipework.

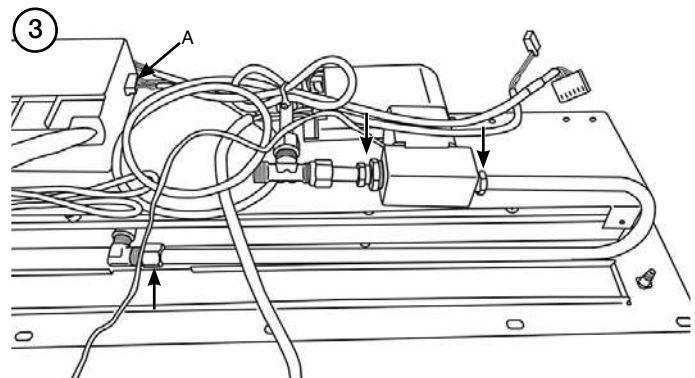

Remove the Solenoid plug from the Control Box (A).

Cut the cable tie. **NOTE the orientation of the cables.**

Replace in reverse order.

**Ensure that the cable ties are replaced.**

## CHANGING BETWEEN GAS TYPES

In order to change between gas types, it will be necessary to change the following components:

- Pilot
- Main Injectors x 6
- Crosslighting Injector
- Gas Valve
- Main Burner x 3

Contact your Gazco retailer for further information.

A kit of parts is available for this. Always quote the Model number and Serial number when ordering any spare parts.

## BAFFLE AND LINERS



### BLACK REED, BRICK EFFECT AND LEDGESTONE LINERS

These lining panel options are available for this product and contains Refractory Ceramic Fibre (RCF), a material which is commonly used for this application.

RCF waste is classed as stable, non-reactive hazardous waste and may be disposed of at a licensed landfill site.

If replacing these items do not break them up. Seal within heavy duty polythene bags and label as RCF waste.

Protective clothing is not required when handling these articles.

If the Liners are visibly broken Gazco recommend using gloves and a face mask to remove the pieces and remove any dust accumulated in and around the appliance before and after working on it with a HEPA filtered vacuum.

If any concerns remain contact Gazco Technical Customer Services to obtain the manufacturers COSHH Data Sheet.

The top baffle must be removed first before accessing the lining set.

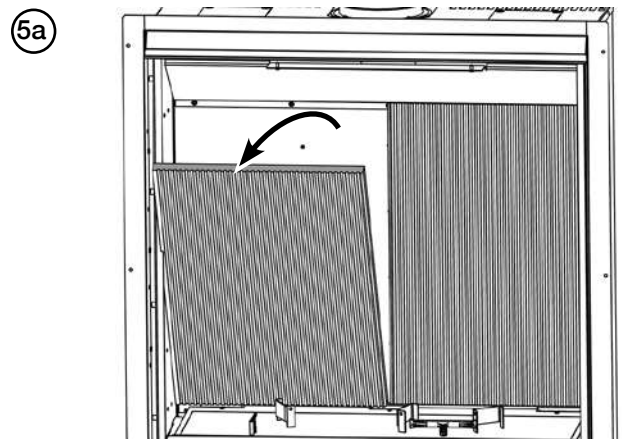
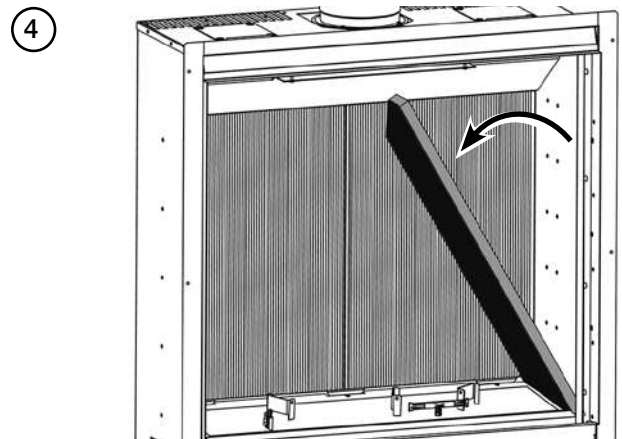
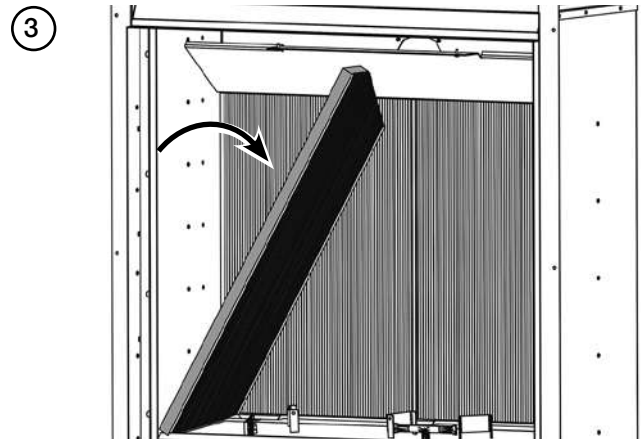
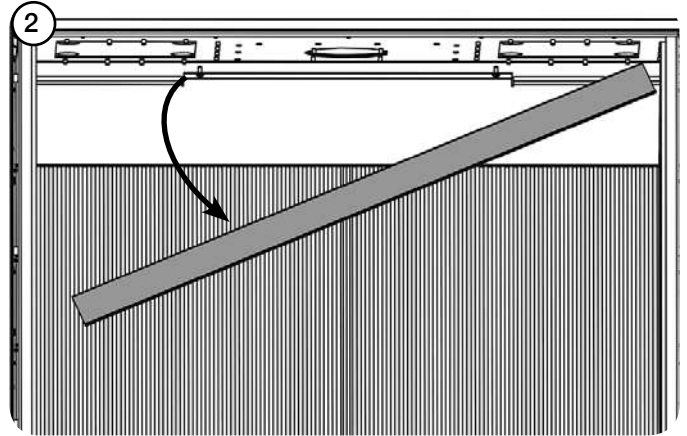
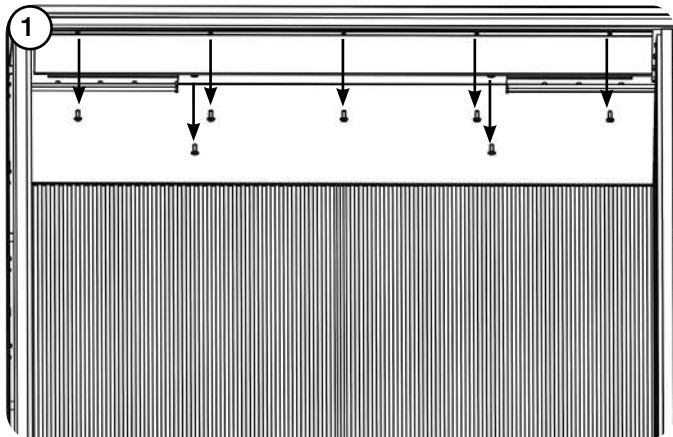



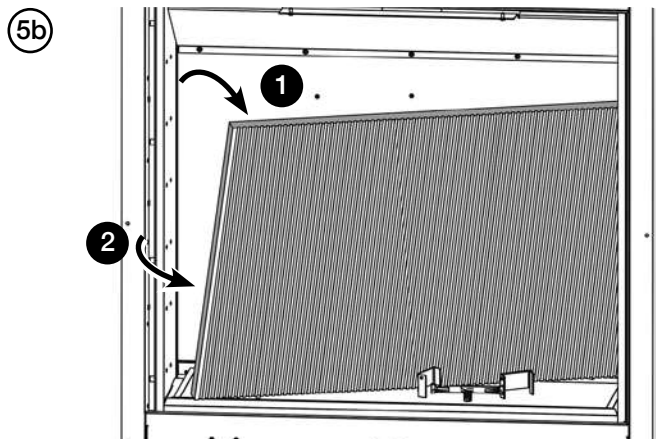

Re-assemble in reverse order.

## REPLACING THE POWER CABLE

**BEFORE UNDERTAKING ANY WORK SWITCH OFF THE APPLIANCE AND ISOLATE THE POWER SUPPLY ENSURING THERE IS NO POWER TO THE APPLIANCE.**

To replace the Power Cable first remove the Main Control Assembly.

Disconnect the 3 cables from the Power Module (A).

**NOTE THE CONFIGURATION OF THE WIRES.**

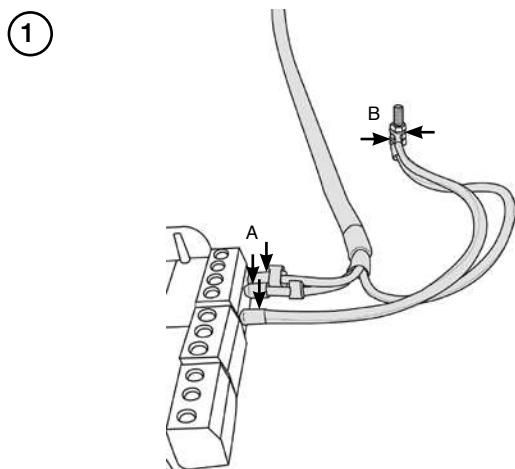

Remove the nuts from the Earth stud and remove the two Ring Terminals (B).

Remove the 2 screws securing the Power Cable Plate to the rear of the firebox.

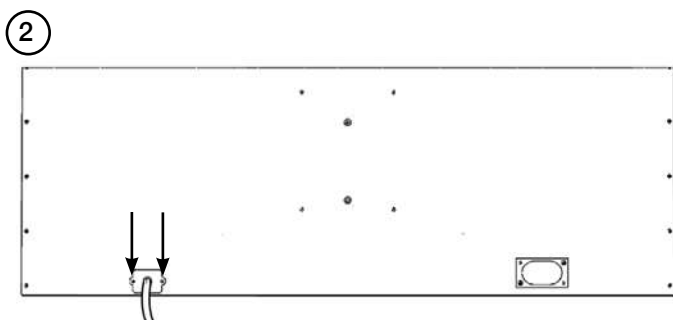

Withdraw the old cable.

Fit the new cable in reverse order ensuring it is rewired in the correct configuration.

## SPARES LIST - MAIN ASSEMBLY

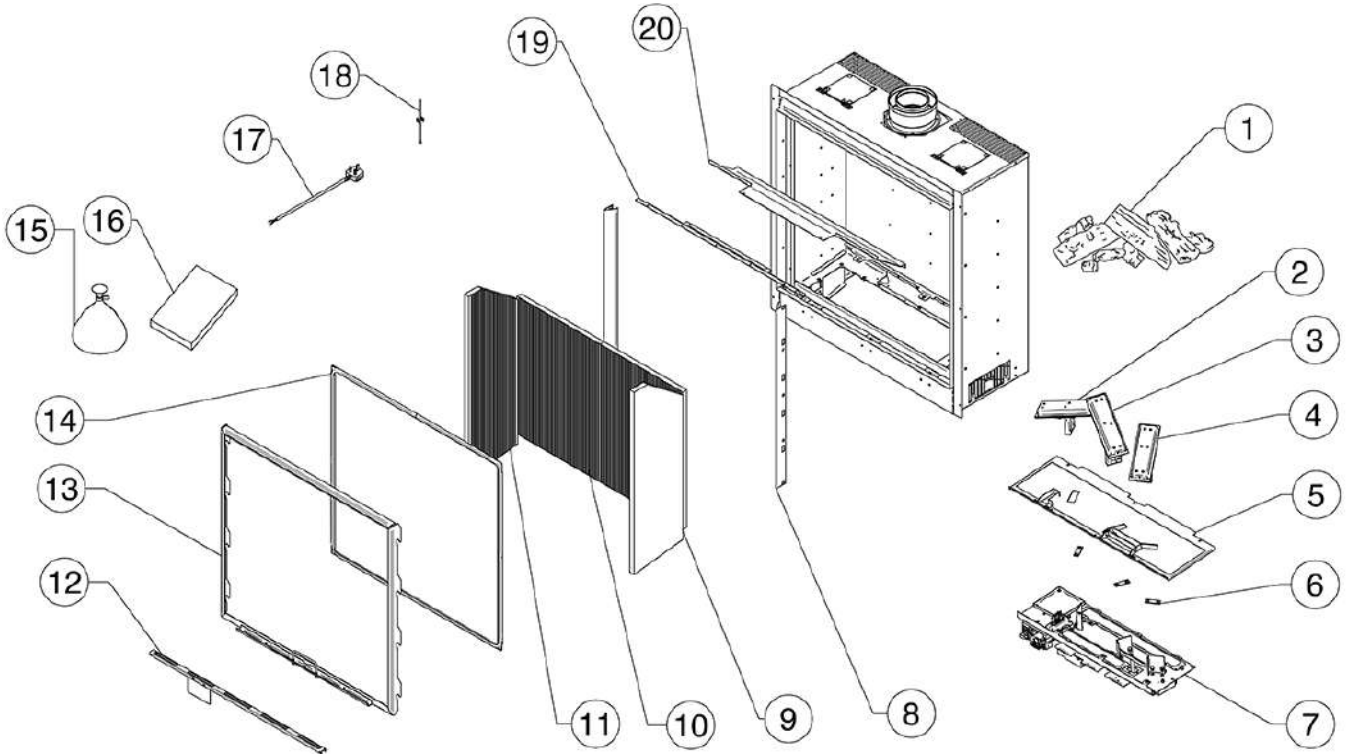

NO.	COMPONENT	PART CODE		QTY.
		NATURAL GAS	LPG	
1	Ceramic Log Set	CE1731		1
2	LH Burner Assembly	GZ15600	GZ15603	1
3	Central Burner Assembly	GZ15601	GZ15604	1
4	RH Burner Mixer Assembly	GZ15602	GZ15605	1
5	Burner Tray & Mesh Assembly	GZ14413		1
6	Injector Seal	CE1738		3
7	Control Assembly	GZ13870N	GZ13870P	1
8	Side Frame Cover	GZ11670		2
9	Black Reed RH Side Panel Assembly	CE1619		1
	Black Glass RH Side Panel Assembly	GZ13616		1
	Ledgestone RH Side Panel Assembly	CE1688		1
	Brick Effect RH Side Panel Assembly	CE1622		1
	Vermiculite RH Side Panel Assembly	CE1616		1
10	Black Reed Rear Panel Assembly	CE1618		2
	Black Glass Rear Side Panel Assembly	GZ13615		1
	Ledgestone Rear Side Panel Assembly	CE1687		1
	Brick Effect Rear Side Panel Assembly	CE1621		1
	Vermiculite Rear Side Panel Assembly	CE1615		2

NO.	COMPONENT	PART CODE		QTY.
		NATURAL GAS	LPG	
11	Black Reed LH Side Panel Assembly	CE1620		1
	Black Glass LH Side Panel Assembly	GZ13617		1
	Ledgestone LH Side Panel Assembly	CE1689		1
	Brick Effect LH Side Panel Assembly	CE1623		1
	Vermiculite LH Side Panel Assembly	CE1617		1
12	Base Infill Angle Assembly	GZ13658		1
13	Door Assembly	GZ14686		1
14	Glass & Ropeseal Assembly	GZ13551		1
15	Amber Crushed Glass	CE1737		1
16	Instruction Kit BF	GZ14529		1
17	UK Mains Lead - 2M	GZ15218		1
18	Earth Cable	EL0051		1
19	Top Baffle (Front)	GZ14412		1
20	Top Baffle (Rear)	GZ14411		1



Due to continual technical improvements please check online or with your Gazco retailer for the most up to date parts lists.

Only use Genuine Gazco spares when servicing your appliance.

All of our essential spare parts and consumable items are available to purchase from our webshop at [www.gazcospares.com](http://www.gazcospares.com).

## SPARES LIST - CONTROL ASSEMBLY

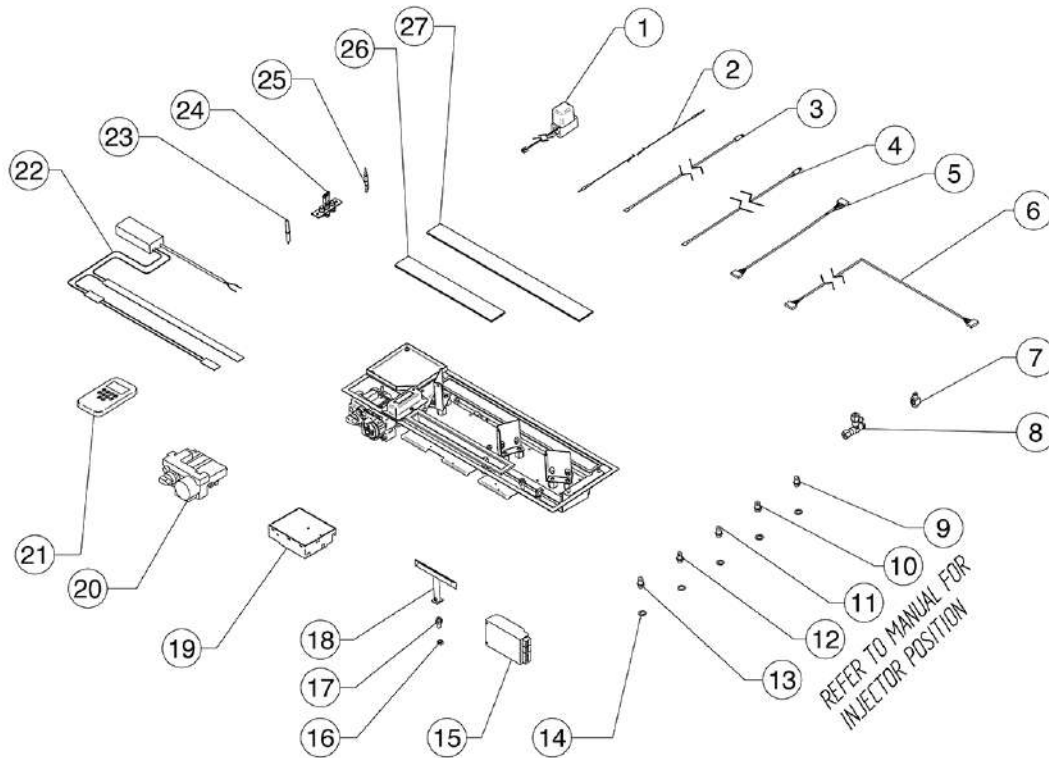

NO.	COMPONENT	PART CODE		QTY.
		NATURAL GAS	LPG	
1	Latching Solenoid Valve	EL0563		1
2	Ignition Cable	GC0125		1
3	Thermo Current Cable	GC0126		1
4	Thermo Current Cable	EL0590		1
5	Module Cable	EL0566		1
6	360mm Connection Cable	GC0133		1
7	Thermocouple Interrupter	GC0124		1
8	Pressure Test Restrictor Elbow	GC0095		1
9	Straight Injector	IN0081 (S120)	N/A	1
10	Straight Injector	IN0087 (S88)	N/A	1
11	Straight Injector	IN0097 (S128)	IN0089 (S63)	1   2
12	Straight Injector	IN0085 (S92)	IN0088 (S60)	2   3
13	Straight Injector	IN0084 (S102)	IN0098 (S78)	1   1

NO.	COMPONENT	PART CODE		QTY.
		NATURAL GAS	LPG	
14	1/8 BSP Fibre Washer	FA0735		6
15	Power Module	EL0672		1
16	M8 x 1 Fine Thread Brass Locknut	FA0740		1
17	Cross Lighting Injector	IN0092	IN0093	1
18	Cross Lighting Burner	GC0180		1
19	Receiver	EL0697		1
20	Control Valve	GC0123		1
21	Thermostatic Handset	EL0655		1
22	LED Lights & Wiring Loom	EL0671		1
23	Electrode	PI0075		1
24	Pilot Injector	PI0069	PI0070	1
25	Thermocouple	PI0074		1
26	Glass LED Cover (Front)	CE1786		1
27	Glass LED Cover (Rear)	CE1855		1



Due to continual technical improvements please check online or with your Gazco retailer for the most up to date parts lists.

Only use Genuine Gazco spares when servicing your appliance.

All of our essential spare parts and consumable items are available to purchase from our webshop at [www.gazcospares.com](http://www.gazcospares.com).

## INFORMATION REQUIREMENT FOR GASEOUS FUEL LOCAL SPACE HEATER

<b>Model</b>		<b>Reflex 75T MKII BF NG</b>	<b>Reflex 75T MKII BF LPG</b>
<b>Fuel</b>	Space Heating Emissions (NOx) - mg / kWh <sub>input</sub> (GCV)	130	130

<b>Heat Output</b>	Nominal Heat Output - $P_{nom}$	8.3kW	8.3kW
	Minimum Heat Output (indicative) - $P_{min}$	2.8kW	3.0kW

<b>Auxiliary Electricity Consumption</b>	At Nominal Heat Output - $e_{lmax}$	0.003kW	0.003kW
	At Minimum Heat Output - $e_{lmin}$	0.003kW	0.003kW
	In Standby Mode - $e_{l_{sb}}$	0.003kW	0.003kW

<b>Useful Efficiency (NCV)</b>	Useful Efficiency at nominal heat output - $\eta_{th,nom}$	92.0%	92.0%
	Useful Efficiency at minimum heat output (indicative) - $\eta_{th,min}$	75.0%	76.0%

<b>Permanent Pilot Flame Power requirement</b>	Permanent Pilot Flame Power requirement (if applicable) - $P_{pilot}$	N/A	N/A
--	---	-----	-----

Type of heat output/room temperature control		
Electronic room temperature control + day timer	Yes	Yes

Other control options (multiple selections possible)		
Room temperature control, with presence detection	No	No
Room temperature control, with open window detection	No	No
With distance control option	No	No
With adaptive start control	No	No
With working time limitation	No	No
With black bulb sensor	No	No

<b>Energy Efficiency Index</b>	<b>88.8%</b>	<b>88.8%</b>
<b>Energy Efficiency Class</b>	<b>A</b>	<b>A</b>

<b>Contact:</b>	Gazco Ltd, Osprey Road, Sowton Industrial Estate, Exeter, EX2 7JG
-----------------	---

**SERVICE RECORDS**

**1ST SERVICE**

Date of Service.....  
 Next Service Due .....  
 Signed.....  
 Retailer's Stamp/GasSafe Registration Number

**3RD SERVICE**

Date of Service.....  
 Next Service Due .....  
 Signed.....  
 Retailer's Stamp/GasSafe Registration Number

**5TH SERVICE**

Date of Service.....  
 Next Service Due .....  
 Signed.....  
 Retailer's Stamp/GasSafe Registration Number

**7TH SERVICE**

Date of Service.....  
 Next Service Due .....  
 Signed.....  
 Retailer's Stamp/GasSafe Registration Number

**9TH SERVICE**

Date of Service.....  
 Next Service Due .....  
 Signed.....  
 Retailer's Stamp/GasSafe Registration Number

**2ND SERVICE**

Date of Service.....  
 Next Service Due .....  
 Signed.....  
 Retailer's Stamp/GasSafe Registration Number

**4TH SERVICE**

Date of Service.....  
 Next Service Due .....  
 Signed.....  
 Retailer's Stamp/GasSafe Registration Number

**6TH SERVICE**

Date of Service.....  
 Next Service Due .....  
 Signed.....  
 Retailer's Stamp/GasSafe Registration Number

**8TH SERVICE**

Date of Service.....  
 Next Due .....  
 Signed.....  
 Retailer's Stamp/Gas Safe Registration Number

**10TH SERVICE**

Date of Service.....  
 Next Service Due .....  
 Signed.....  
 Retailer's Stamp/GasSafe Registration Number







Gazco Ltd, Osprey Road, Sowton Industrial Estate, Exeter, Devon, England EX2 7JG

Tel: (01392) 474011 Fax: (01392) 219932 E-mail: [info@gazco.com](mailto:info@gazco.com) [www.gazco.com](http://www.gazco.com)

E & O E



PR2271